

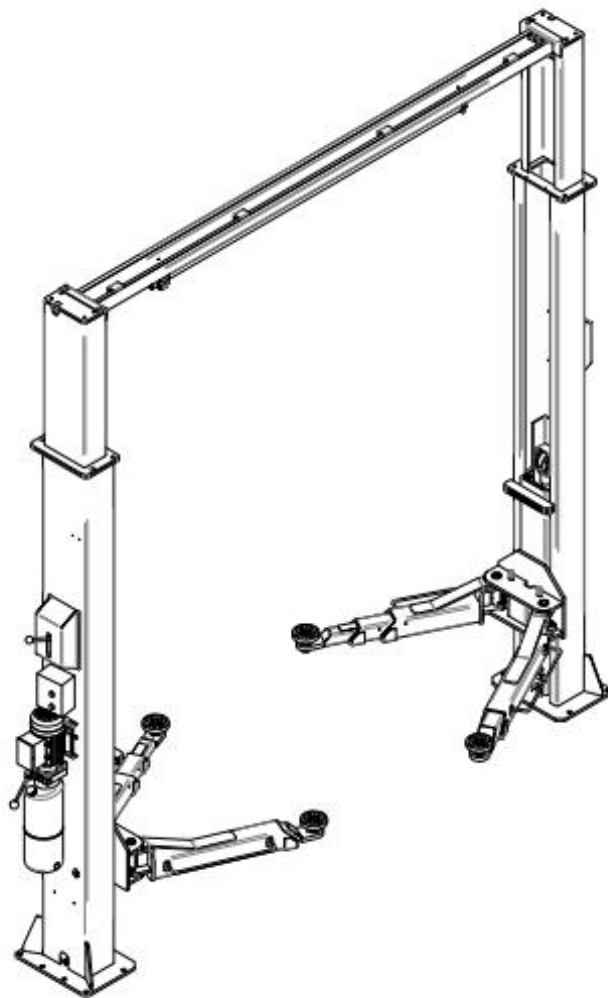

PROTEC

Instructions and Original Manual

FOR HYDRAULIC TWO-POST LIFT



The specifications stated on this brochure are not binding. We reserve the right to change the specification without notice

Trademark Information

PROTEC is a registering trade mark of Protec Equipment Canada (short for PROTEC) in Canada.

All other PROTEC trademarks, service marks, domain names, logos, and company names referred to in this manual are either trademarks, registered trademarks, service marks, domain names, logos, company names of or are otherwise the property of PROTEC or its affiliates. In countries where any of the PROTEC trademarks, service marks, domain names, logos and company names are not registered, PROTEC claims other rights associated with unregistered trademarks, service marks, domain names, logos, and company names. Other products or company names referred to in this manual may be trademarks of their respective owners. You may not use any trademark, service mark, domain name, logo, or company name of PROTEC or any third party without permission from the owner of the applicable trademark, service mark, domain name, logo, or company name. You may contact PROTEC by visiting PROTEC at <http://www.protecequipment.ca>, or writing to 5-2410 Dunwin Drive, Mississauga, Ontario, Canada L5L 1J9, to request written permission to use Materials on this manual for purposes or for all other questions relating to this manual.

Copyright Information

Copyright © 2014 by Protec Equipment Canada. All rights reserved. No part of this publication may be reproduced, stored in a retrieval system, or transmitted in any form or by any means, electronic, mechanical, photocopying, recording or otherwise, without the prior written permission of PROTEC. The information contained herein is designed only for the use of this unit. PROTEC is not responsible for any use of this information as applied to other units.

Neither PROTEC nor its affiliates shall be liable to the purchaser of this unit or third parties for damages, losses, costs, or expenses incurred by purchaser or third parties as a result of: accident, misuse, or abuse of this unit, or unauthorized modifications, repairs, or alterations to this unit, or failure to strictly comply with PROTEC operating and maintenance instructions.

PROTEC shall not be liable for any damages or problems arising from the use of any options or any consumable products other than those designated as Original PROTEC Products or PROTEC Approved Products by PROTEC.

General Notice

Other product names used herein are for identification purposes only and may be trademarks of their respective owners. PROTEC disclaims any and all rights in those marks.

This unit is made for the purpose of persons who have special techniques and certifications.

Disclaimer

- To take full advantage of the unit, you should be familiar with tires of various kinds.
- All information, illustrations, and specifications contained in this manual are based on the latest information available at the time of publication. The right is reserved to make change at any time without notice.

Safety Precautions

- This manual is a necessary part of the product. Please read carefully.
- Keep the manual for later use when maintaining the machine.
- This machine can only be used for the designated purposes. Never use it for any other purpose. The manufacturer is not held responsible for the damage incurred by improper use or use other than the intended purpose.
- The equipment can only be operated by qualified personnel with special training. Modification to any components or parts, or use the machine for other purpose without either obtaining the agreement from the producer, or observing the requirement of the instructions may lead to direct or indirect damage to the equipment.
- This machine should be installed on the stable ground.
- Keep the back panel 0.5m away from the wall for good ventilation. Enough room should be left on both sides of the machine for convenient operation.
- Do not put this machine in a place with high temperature or moisture, or near the heating system, water tap, air-humidifier or furnace.
- Do not put the machine near the window with sunlight. Protect the unit with a curtain or shield if necessary.
- Avoid lots of dust, ammonia, alcohol, thinner or spraying binder.
- People who are not operating the machines should be kept away when it is used.
- Use appropriate equipment and tools, protective and safety equipment, including eyeglasses, earplugs and working boots.
- Pay special attention to the safety marks on the machine.
- Do not touch or approach the moving parts by hand during operating.
- Do not remove the safety device or override it.
- Use #2 lithium lubricants (grease) only within the safety range. Refer to the appendix for the safety data.
- Before moving the tire changer, contact maintenance personnel.
- The product is better used under the following conditions:
 - Temperature: 0°C -45°C
 - Relative humidity: 30-95%

Index:

PACKING, TRANSPORT AND STORAGE	5
PACKING	5
LIFTING AND HANDLING	5
STORAGE	6
STACKING	6
UNPACKING	6
CHAPTER 1 – LIFT DESCRIPTION	7
1.1 FIXED STRUCTURE.....	8
1.2 MOVING UNITS.....	8
1.3 LIFT UNIT.....	8
1.4 HYDRAULIC POWER UNIT.....	9
1.5 CONTROL BOX	9
1.6 SAFETY FEATURES.....	9
2.1 DIMENSIONS AND OVERALL CLEARANCES	11
2.2 ELECTRIC PRINCIPLE DIAGRAM	12
2.3 HYDRAULIC SYSTEM	13
2.3.1 HYDRAULIC PRINCIPLE DIAGRAM.....	13
2.3.3 HYDRAULIC OIL.....	13
2.4 VEHICLE WEIGHT	14
2.5 MAXIMUM DIMENSIONS OF VEHICLES TO BE LIFTED	14
3.1 GENERAL PRECAUTIONS	16
3.2 RISKS OF ELECTRIC SHOCK.....	17
3.3 RISKS AND PROTECTIVE DEVICES.....	17
3.4 LONGITUDINAL AND LATERAL MOVEMENT.....	17
3.5 RISKS WHILE THE VEHICLE IS BEING RAISED.....	18
3.6 RISKS TO PERSONELL	18
3.6.1 RISK OF CRUSHING (OPEARATOR).....	19
3.6.2 RISK OF CRUSHING (PERSONNEL).....	20
3.6.3 RISK OF IMPACT.....	20
3.6.4 RISK DUE TO VEHICLE MOVEMENT.....	21
3.6.5 RISK OF VEHICLE FALLING FROM LIFT.....	21
3.6.6 SLIPPING.....	22
3.6.7 RISK OF ELECTRIC SHOCK.....	22
3.6.8 RISK RELATED TO INAPPROPRIATE LIGHTING.....	23
3.6.9 RISK OF COMPONENT FAILURE DURING OPERATION.....	23
3.6.10 RISK RELATED TO IMPROPER USE.....	23
CHAPTER 4 - INSTALLATION	25
4.1 INSTALLATION REQUIREMENTS	25
4.2 LIGHTING	26

4.3 FLOOR	26
4.4 ASSEMBLY	26
4.4.1 POSTS ASSEMBLY	27
4.4.2 LIFT CABLE ASSEMBLY	27
4.4.3 HYDRAULIC SYSTEM ASSEMBLY	28
4.4.4 ARM ASSEMBLY	28
4.4.5 ELECTRIC MOTOR CONNECTION	29
4.5 TESTING AND CHECKING TO PERFORM PRIOR TO START-UP	30
4.5.1 MECHANIAL TESTS	30
4.5.2 ELECTRICAL TESTS	30
4.5.3 OPERATING OF THE FOLLOWING DEVICES	30
4.5.4 HYDRAULIC OIL TEST	30
4.5.5 ROTATION DIRECTION TEST	30
4.6 SET UP	30
4.6.1 VACUUM TEST (without vehicles loaded)	31
4.6.2 LOAD TESTS	31
CHAPTER 5 - OPERATIONS AND USE	32
5.1 CONTROLS	32
5.1.1 UP BUTTON	◦
5.1.2 DOWN LEVER	◦
5.2 OPERATING SEQUENCE	◦
5.2.1 LIFTING	◦
5.2.2 PARKING	◦
5.2.3 LOWERING	◦
CHAPTER 6 – MAINTENANCE	33
6.1 PRECAUTIONS	33
6.2 PERIODIC MAINTENANCE	34
6.2.1 OPERATION FREQUENCY	34
6.2.2 EVERY MONTH	34
6.2.3 EVERY 3-MONTHS	34
6.2.4 EVERY 6-MONTHS	35
6.2.5 EVERY 12-MONTHS	35
6.3 PERIODIC LUBRICATION	36
CHAPTER 7 - TROUBLESHOOTING	37
7.1 TROUBLESHOOTING GUIDE	37
7.2 POSSIBLE PROBLEMS AND SOLUTIONS	37
CHAPTER 8 - STRUCTURE AND ACCESSORIES LIST	39
8.1 STRUCTURE DIAGRAMS	39
CHAPTER 9 – Regular information	0

PACKING, TRANSPORT AND STORAGE

PACKING

GROSS WEIGHT	693kg
NET WEIGHT	673kg

Nameplate

LIFTING AND HANDLING

The packed boxes may be lifted and moved with a Fork Lift. If a crane is used, harness with at least 2 slings.

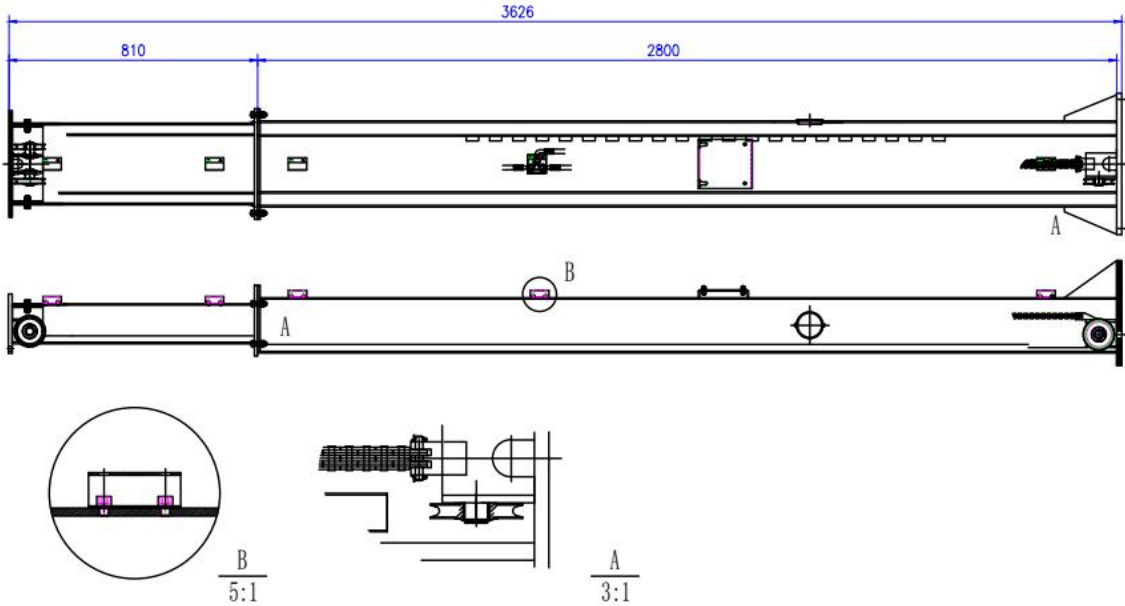

Fig.1

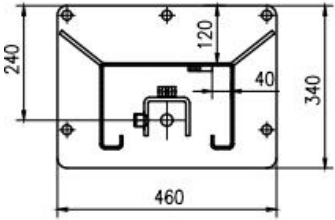

Fig.2

Accessory dimension	750×360×260mm
---------------------	---------------

STORAGE

Packaged Lifts should always be kept in a covered, protected place, at a temperature between -10° C and +40° C. They must not be exposed to direct sunlight or rain.

STACKING

The type of packaging allows the Lifts to be stacked up to 3 crates high. Crates may be stacked one upon the other on trucks if properly positioned and provided they are restrained to prevent falling.

UNPACKING

Check that the Lift has not been damaged during transport and that all parts listed are present. The crates must be opened using all possible precautionary measures to avoid damaging the Lift or its parts. Ensure that parts do not fall from the crate whilst opening.



WARNING INTRODUCTION

This manual has been prepared for workshop personnel and technicians responsible for routine maintenance. This manual must be read prior to carrying out any operation with the Lift. This manual contains important information regarding the personal safety of operator and maintenance workers as well as Lift safety.

THE PERSONAL SAFETY OF OPERATORS AND MAINTENANCE WORKERS

4500kg NB: The rated load of the Lift is 4500kg.

Operatio instruction



This symbol conveys the attention that should be taken to avoid electrical hazards.

PRESERVING THE MANUAL

The manual is an integral part of the Lift, which should always accompany the Lift even if the unit is sold. The manual must be kept in the vicinity of the Lift in an easily accessible place so that the operator and maintenance staff are able to locate and consult the manual swiftly at any time.

CAREFUL READING OF CHAPTER 3, WHICH CONTAINS IMPORTANT INFORMATION AND SAFETY WARNINGS, IS HIGHLY RECOMMENDED.

CHAPTER 1 – LIFT DESCRIPTION

The 2-post electro-hydraulic Lift is a fixed installation. Mount the vehicle according to the diagram using the anchor bolts supplied by the manufacturer.

The Lift consists of the following main parts:

1. Fixed structure (posts + beams)
2. Lift carriage (Lift vehicle + arms)
3. Lift units (2 hydraulic cylinders + power unit)
4. Control station
5. Safety devices

Figure 3 illustrates the various parts of the Lift and the work areas reserved for use by operators around the Lift.

Command side: this side of the Lift includes the area reserved for the operator to access the control box.

Service side: this is the opposite side of the command side.

Front side: the side with the short arms.

Rear side: the side with the long arms.

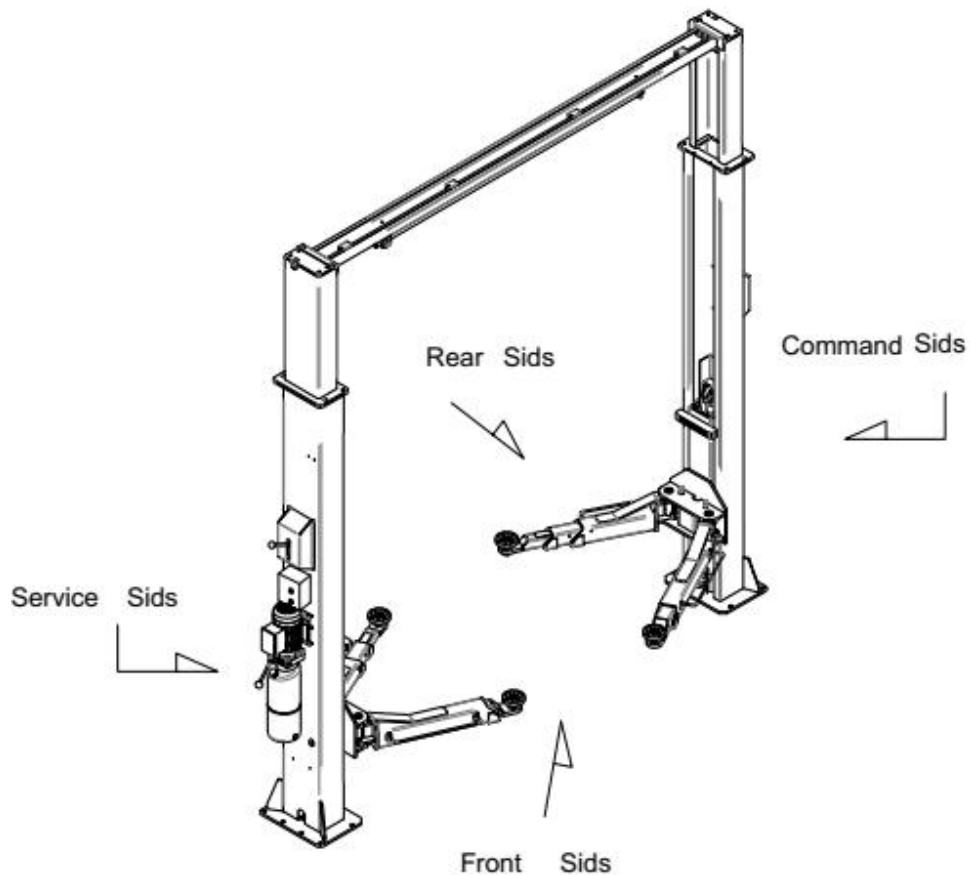

Fig. 3

1.1 FIXED STRUCTURE (Fig. 4)

This structure consists of:

1. Two posts built with combined bent steel. The base is welded to a drilled plate to be anchored to the floor, using the foundation bolts. The control plate and the hydraulic power unit are attached to the command post. Inside each post are the moving parts to lift the vehicles.

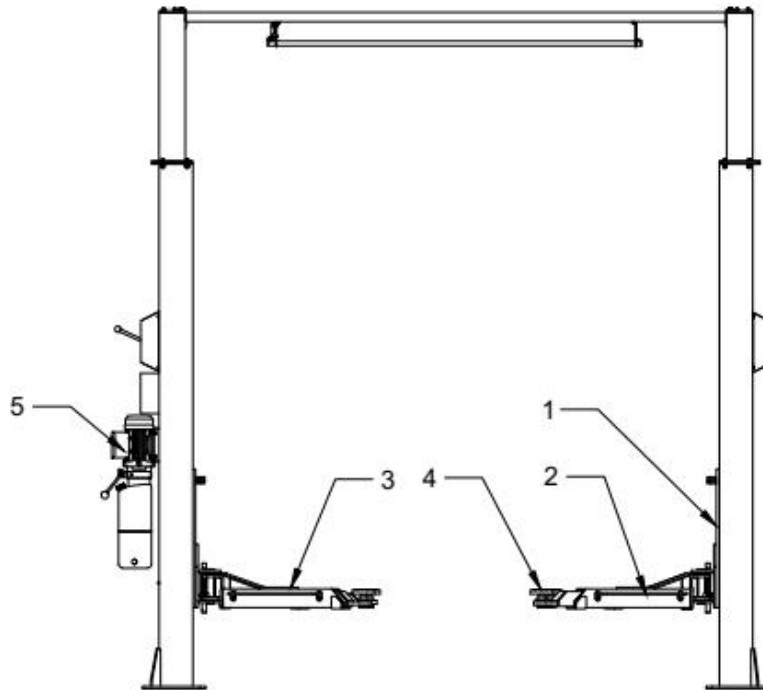

Fig. 4

1.2 MOVING UNITS (Fig. 4)

Each unit consists of:

1. Lift carriage (1) built with welded steel plate and connected at the top of the hydraulic cylinder and the posts. The Lift carriage moves along the post, guided by plastic sliding pads, located inside the post itself.
2. Two telescopic arms, one long (2) and one short (3), built with square steel with a rubber screw type pads (4) at each end that can be height adjusted to hold the car.

1.3 LIFT UNIT (Fig. 4)

The Lift Unit consists of:

1. Two hydraulic cylinders (5), to lift the vehicle anchored to the post.

2. One hydraulic pump station (see fig.5). Mount on the command post.

1.4 HYDRAULIC POWER UNIT (FIG.5)

1. An electric motor (1)
2. A geared hydraulic pump (2)
3. Descent manual valve pole (3) equipped with a manual oil drain valve (see the use and maintenance chapter)
4. An adjusting pressure valve (4)
5. Oil tank (5)
6. Two hoses for the delivery of oil. (6)

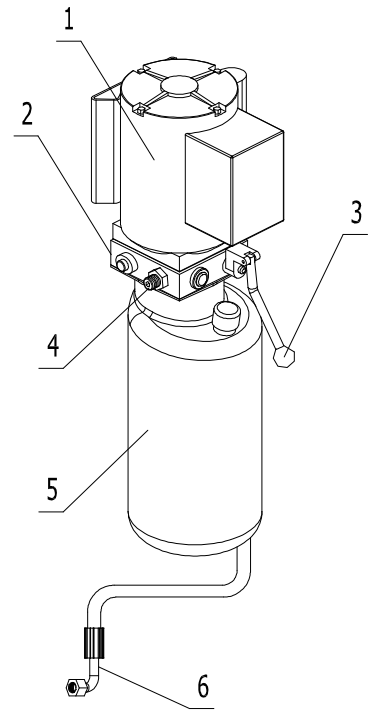

Fig.5

Note: The pressure of the oil delivery pipe may be not less than 40Mpa

1.5 CONTROL BOX (Fig.6)

The panel that houses the electric control box contains the following:

- 1 Rise push button
- 2 Descent manual valve pole
- 3 Key lock / Isolating switch

The hydraulic power unit consists of:

1.6 SAFETY FEATURES

The safety features include:

- 1 Mechanical safety locking system every 80mm
- 2 Arm locking system
- 3 Four foot guards located on the arms
- 4 Wire cables that operate in synchronized time to control the vehicle movement.
- 5 Control switch
- 6 Flame proof valve
- 7 Circuit Breaker

These safety devices will be described in further detail in the following chapters

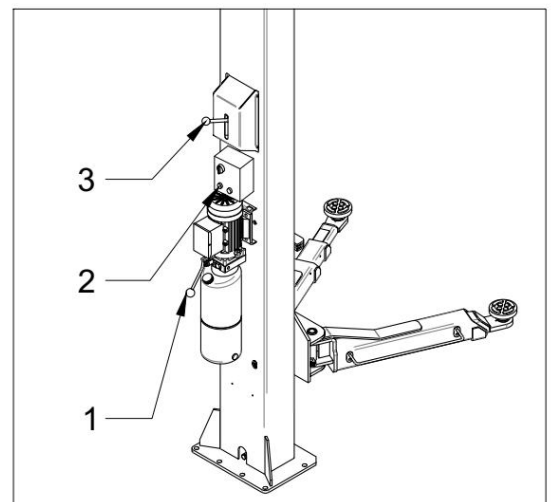

CHAPTER 2 - TECHNICAL SPECIFICATIONS

Lifting capacity	4500kg
Car max Lifting height	1850mm
Lift min stand height	95mm
Clearance between posts	2820mm
Overall height	3640mm
Overall width (total)	3360mm
Long arm maximum length	1390mm
Long arm minimum. length	890mm
Short arm maximum length	1050mm
Short arm minimum length	740mm
Rise time with three-phase motor	≤75sec
Rise time with single-phase motor	≤75sec
Descent time	18sec≤t≤60sec
Noise	70db (A) 1m
Operating temperature	10° C /+50° C
Work environment:	Closed room
Relative humidity	90%
Sea level height	≤3500m
Gross weight	693
Net weight	672

2.1 DIMENSIONS AND OVERALL CLEARANCES

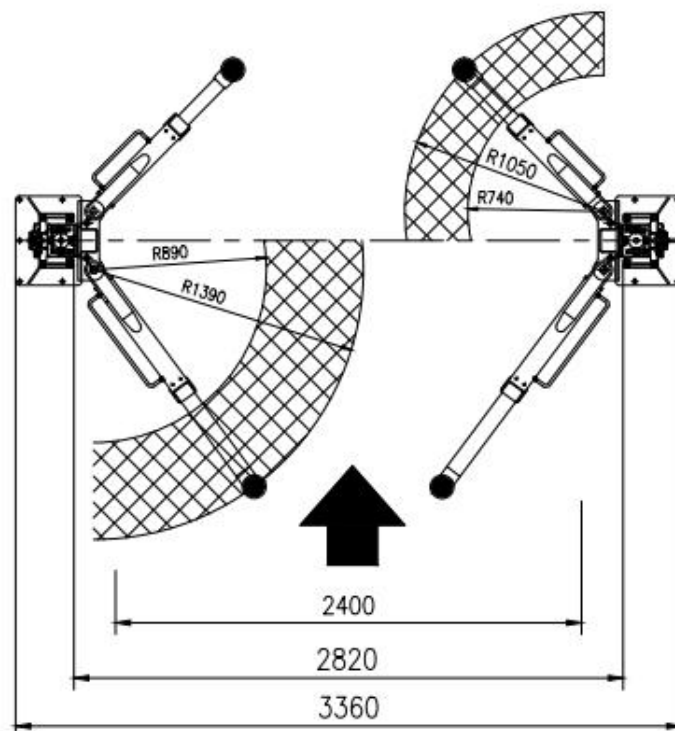
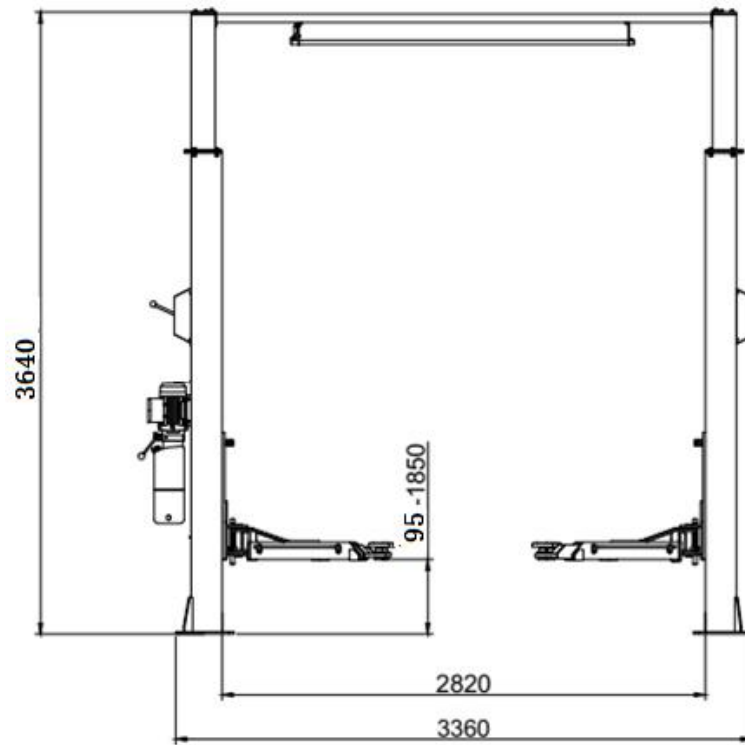
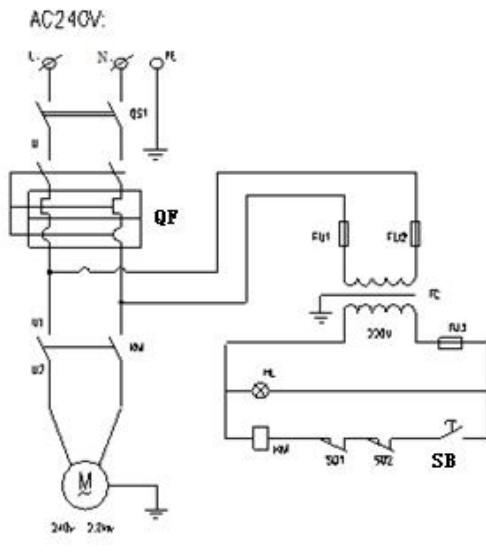
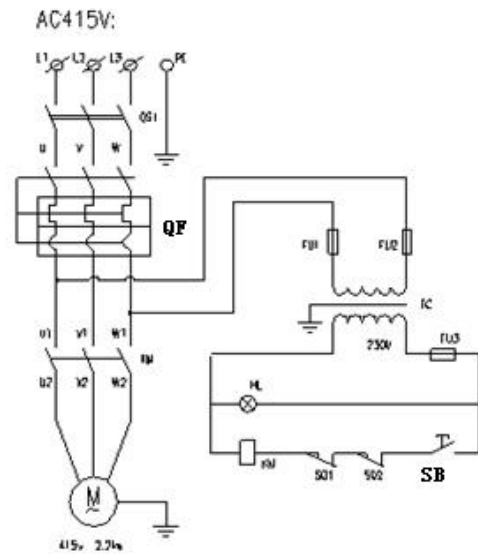

Fig. 8

2.2 ELECTRIC PRINCIPLE DIAGRAM



SINGLE PHASE



THREE PHASE

MOTOR AND ASSEMBLY

SB	Up button
QS	Main switch
QF	Breaker 32A
FU1, FU2	Fuse 10A
FU3	Fuse 2A
M	Motor
SQ	Limit switch
HL	Indicator lamp
TC	Transformer

SB	Up button
QS	Main switch
QF	Breaker 20A
FU1, FU2	Fuse 10A
FU3	Fuse 2A
M	Motor
SQ	Limit switch
HL	Indicator lamp
TC	Transformer

Refer to the above circuit diagram for the connection of the motor.

The rotation of the motor should be towards the direction of the pump, if not, amend the connection of motor.

2.3 HYDRAULIC SYSTEM

2.3.1 HYDRAULIC PRINCIPLE DIAGRAM

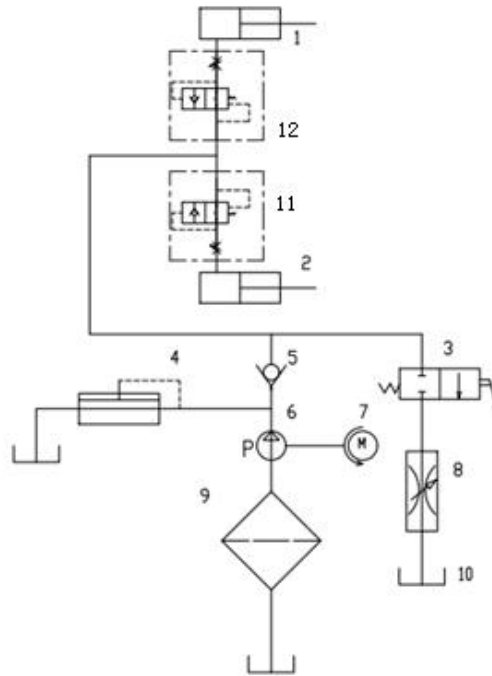

Fig.9

2.3.2 HYDRAULIC ASSEMBLY

(1)	Oil cylinder
(2)	Oil cylinder
(3)	Descending valve
(4)	Slipping valve
(5)	Retaining valve
(6)	Pump station
(7)	Motor
(8)	Throttle valve
(9)	Oil filter
(10)	Oil Tank
(11)	Anti-explosion valve
(12)	Anti-explosion valve

Working Pressure	16—18mpa
-------------------------	-----------------

2.3.3 HYDRAULIC OIL

The oil reservoir contains hydraulic mineral oil in accordance with ISO/DIN 6743/4 with a level of contamination according to ISO 4406, for example Valvoline Ultramax 32 or equivalent.

2.4 VEHICLE WEIGHT

The maximum Lift weight is 3600kg.

2.5 MAXIMUM DIMENSIONS OF VEHICLES TO BE LIFTED

Max width	2400mm
Max wheel base	3000mm

The underbody of cars with low ground clearance may interfere with the structure of the Lift. Pay particular attention in the case of low body sports cars.

Always keep the capacity of the Lift in mind. The dimensions of the vehicle will determine THE SAFETY area.

The diagrams below include the criteria for defining the limits of use of the Lift.

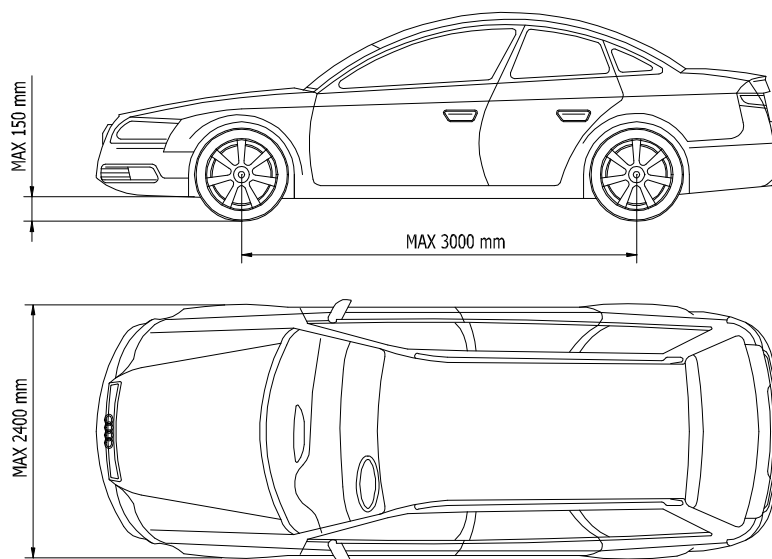

Fig.10 Minimum and maximum dimensions

CHECK MAXIMUM LOAD CAPACITY AND LOAD DISTRIBUTION IN CASE OF LARGER VEHICLES AND MAXIMUM WEIGHT OF THE VEHICLE TO BE LIFTED

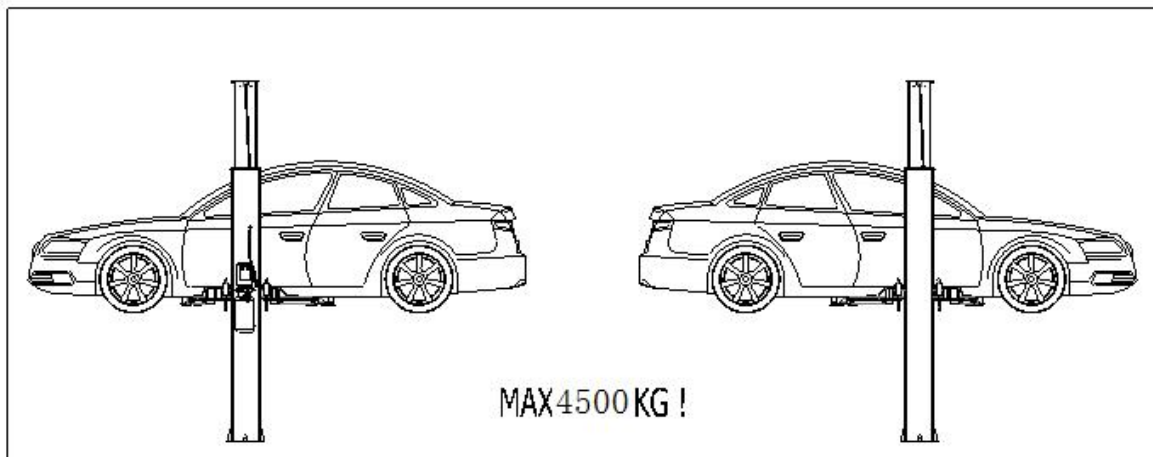

Fig.11 Weight distribution

CHAPTER 3 - SAFETY

It is vital to read this chapter of the manual carefully from beginning to end as it contains important information regarding the risks that the operator and the maintenance fitter may be exposed to in the event that the Lift is used incorrectly.

The following text contains clear explanations regarding certain situations of risk or danger that may arise during the operation or maintenance of the Lift, the safety devices installed and the correct use of such systems and operating procedures including general and specific precautions to eliminate potential hazards.

WARNING

The Lift is designed and built to lift vehicles and hold them in the elevated position in a closed workshop. All other uses are unauthorised; in particular, **the Lift is not suitable for:**

- Washing vehicles
- Creating raised platforms or lifting personnel
- Use as a makeshift press for the purpose of crushing
- Use as goods lift
- Use as a jack for partial lifting of vehicles

THE MANUFACTURER AND ITS DISTRIBUTORS RENOUNCE ALL LIABILITY FOR INJURY TO PERSONS OR DAMAGE TO VEHICLES AND OTHER PROPERTY CAUSED BY THE INCORRECT AND UNAUTHORISED USE OF THE LIFT.

During raising and descent movements, the operator must remain in the command station as defined in figure 12. The presence of persons inside the danger zone indicated in the same figure is strictly prohibited. The presence of persons beneath the vehicle during operations is permitted only when the vehicle is parked in the elevated position.

DO NOT USE THE LIFT WITHOUT PROTECTION DEVICES OR WITH THE PROTECTION DEVICES INHIBITED. FAILURE TO COMPLY WITH THESE REGULATIONS CAN CAUSE SERIOUS INJURY TO PERSONS, AND IRREPERABLE DAMAGE TO THE LIFT AND THE VEHICLE BEING LIFTED.

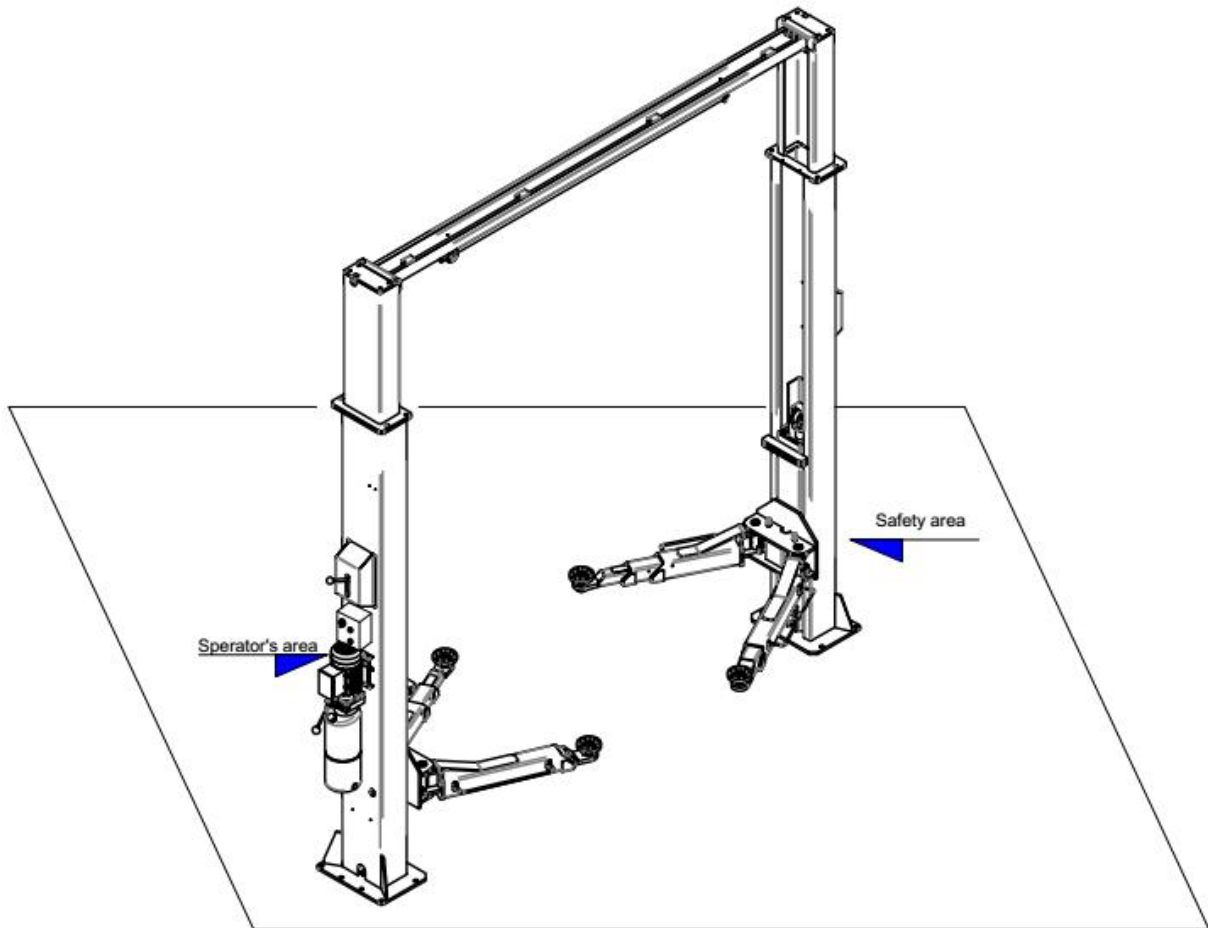

Fig.12 working areas

3.1 GENERAL PRECAUTIONS

The operator and the maintenance fitter are required to observe Occupational Health and Safety legislation in force relating to accident prevention.

Furthermore, the operator and the maintenance fitter must:

1. Always work in the scheduled working area as shown in this manual
2. Never remove or deactivate the guards, mechanical, electrical or other types of safety devices.
3. Read the safety notices affixed to the lift and the safety information in this manual.

Safety wording referred to in this manual are as follows.

DANGER: Indicates imminent danger that can result in serious injury or death

WARNING: Indicates situations and/or types of maneuvers that are unsafe and can cause injuries or death.

CAUTION: Indicates situations and/or types of maneuvers that are unsafe and can cause minor injury to persons and/or damage the Lift or the vehicle.

3.2 RISKS OF ELECTRIC SHOCK

Specific safety notice affixed to the Lift in areas where the risk of electric shock is high.

3.3 RISKS AND PROTECTIVE DEVICES

We shall now examine the risks to which the operator and the maintenance fitters may be exposed when the vehicle is immobilized in the raised position, together with the protective devices adopted by the manufacture to reduce all such hazards.

3.4 LONGITUDINAL AND LATERAL MOVEMENT

The vehicle chosen must be suitable for safe lifting and moving, bearing in mind the dimensions and weight. Once the vehicle is raised, the load can not be moved backward or forward as this can cause the vehicle to fall from the lift. ■

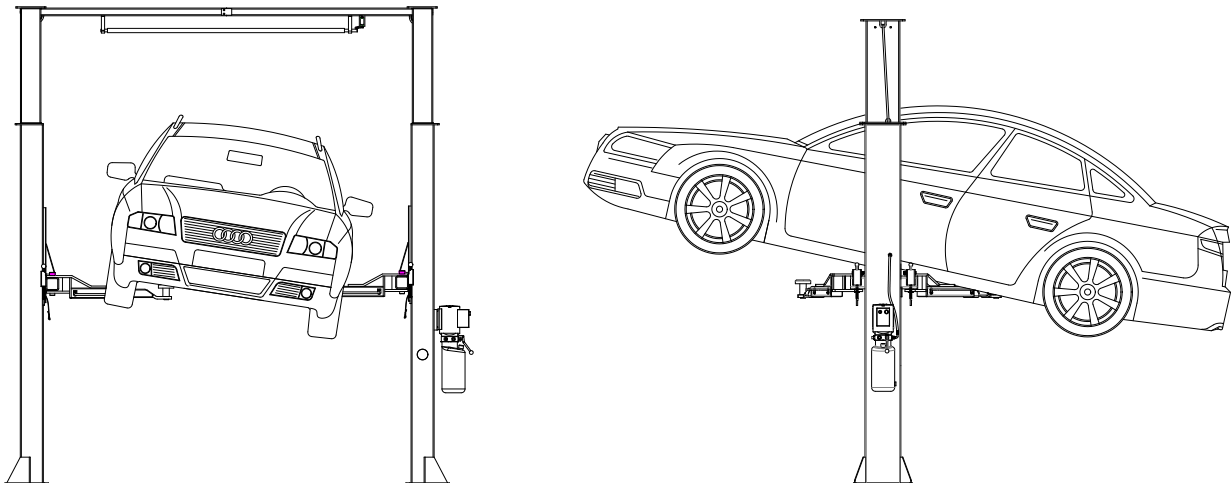

Fig.13 Risk of falling vehicle

WARNING

DO NOT ATTEMPT TO MOVE THE VEHICLE WHEN IT IS RESTING ON THE LIFT PADS

It is important to position the vehicle on the Lift so that the weight is correctly distributed on the arms. For personal and equipment safety, it is important that:

1. People remain inside the safety area while the vehicle is being raised
2. The engine is off and the safety lock is engaged
3. The vehicle is correctly positioned.
4. Vehicles being raised do not exceed the rated capacity and overall dimensions.

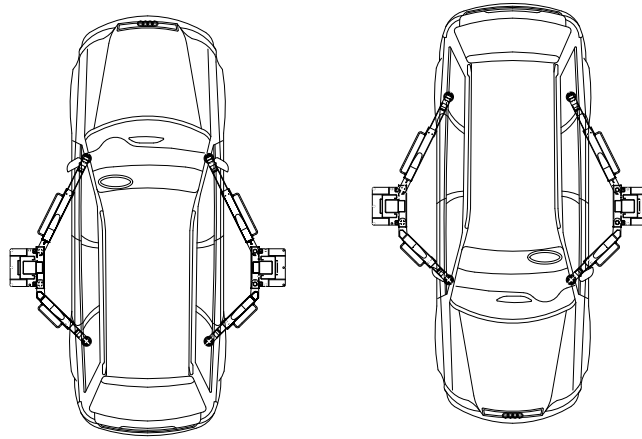

Fig.14 Correctly loaded vehicle

3.5 RISKS WHILE THE VEHICLE IS BEING RAISED

The following safety devices have been installed to protect against overloading and equipment failure:

1. The thermal relay in the electric box will trip if the motor is overloaded
2. The pressure regulating valve, located on the hydraulic oil power unit, will trip if the lift is overloaded
3. In case of a major oil leak (a broken line), the blocking valves at the bottom of each cylinder will trip
4. In the case of the equalizing cables loosening and/or breaking, the hydraulic system and the lift chain will maintain balance. The lift chain and the steel wire will balance each other.
5. If the hydraulic cylinder breaks, the block on the command post is locked by the mechanical lock, and immediately stops the carriages preventing their descent
6. If the moving part exceeds its travel distance, the limit switch located on the upper part of the command post will stop the hydraulic cylinder from bottoming out. In case of a failing limit switch, the hydraulic cylinders will move to the end of their stroke, which will be past the normal upper stop position. Therefore it is the operator's responsibility to ensure that there is adequate space above the vehicle being lifted to avoid collision with the roof.

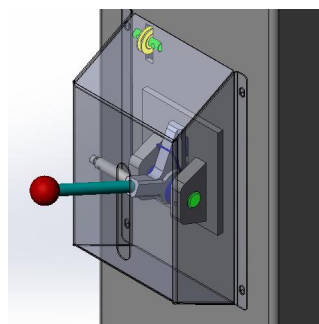

Fig. 15

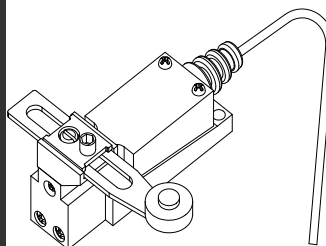
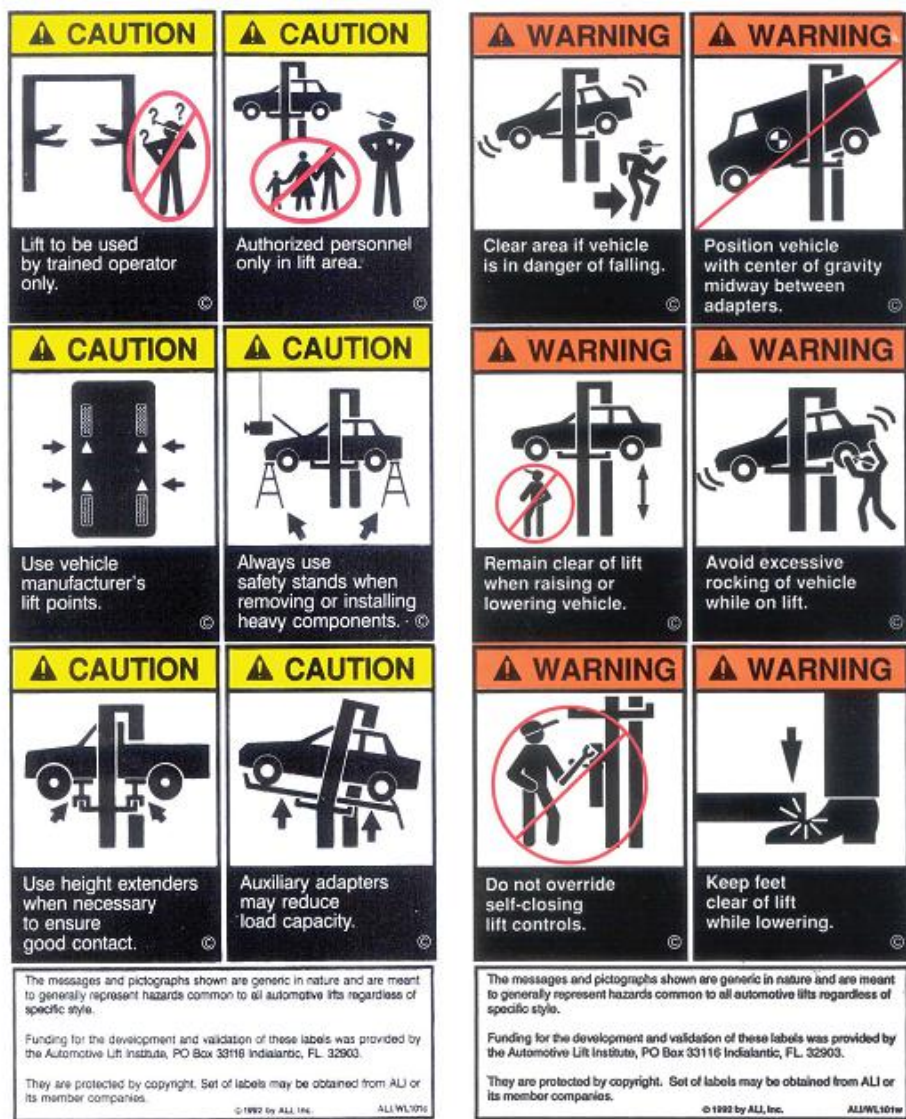

Fig. 16

3.6 RISKS TO PERSONELL

This paragraph illustrates risks to which the operator, maintenance worker, or any person near the operating area of the Lift may be exposed in the case of improper use of equipment.



3.6.1 RISK OF CRUSHING (OPEARATOR)

The operator controlling the lift must remain in the specified position at the command panel when the platform and the vehicle are descending. The operator must never be partly or completely underneath the moving structure. During this phase the operator must remain in the command zone (fig.17).

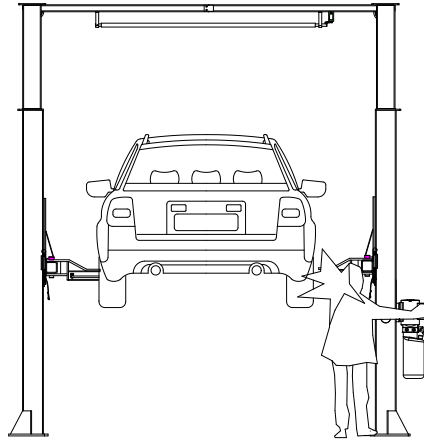
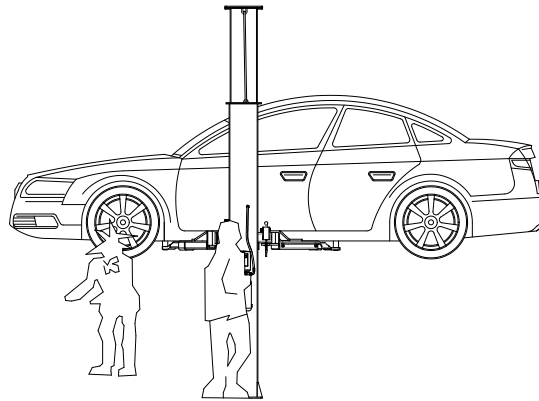

Fig.17

3.6.2 RISK OF CRUSHING (PERSONNEL)

When the platform and the vehicle are descending, personnel are prohibited from entering the area beneath the moving parts of the lift. (fig.18). The lift operator must not start the maneuver until it has been clearly established that there are no personnel in potentially



dangerous positions.

Fig.18

3.6.3 RISK OF IMPACT

Risk of impact caused by parts of the lift or the vehicle that are positioned at head height. When, due to operational reasons, the lift is immobilised at relatively low elevations (less than 1.75m from the ground) personnel must be careful to avoid impact with parts of the lift not marked with special hazard colouring (Fig. 19).

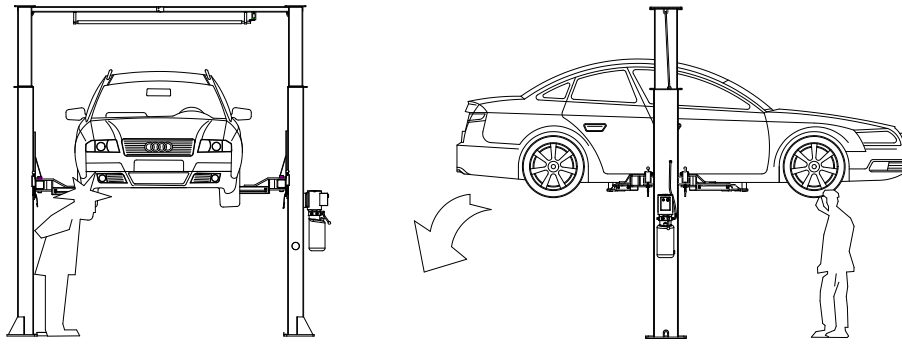

Fig.19

3.6.4 RISK DUE TO VEHICLE MOVEMENT

Movement may be caused during operations, which involve force sufficient to move the vehicle (Fig. 20). If the vehicle is of considerable dimensions or weight, movement may lead to overload or unbalancing. The weight and dimensions of the Lift calculated in advance, must be taken into consideration to avoid such an occurrence.

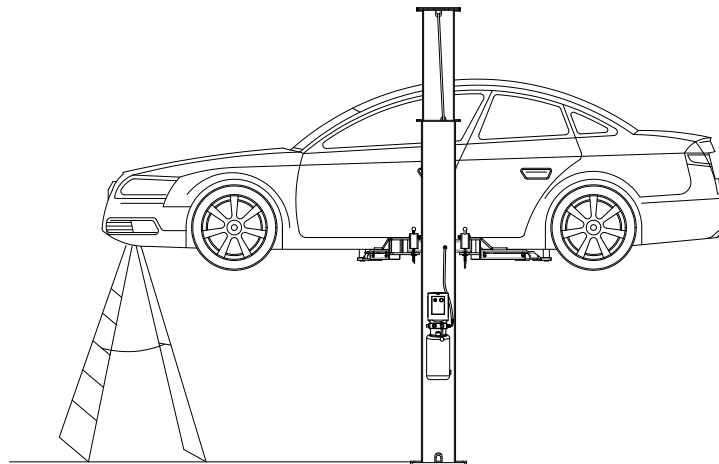

Fig. 20

3.6.5 RISK OF VEHICLE FALLING FROM LIFT

Caution should be taken when positioning the vehicle on the lift pads. The incorrect positioning of the vehicle on the lift pads can cause the vehicle to fall from the lift. (fig. 22) When loading the vehicle, place the lift arms in the position to give the correct center of gravity, to avoid such an occurrence.

ENSURE THT YOU PAY CLOSE ATTENTION TO LOADING OF THE CAR ON THE LIFT ARM TO GET THE CORRECT BALANCE.

**NEVER BOARD THE VEHICLE AND/OR TURN THE ENGINE ON WHEN LIFT IS RAISED.
NEVER LEAN OBJECTS AGAINST THE POSTS OR LEAVE THEM IN THE AREA WHERE MOVING PARTS ARE LOWERED.**

The above actions could hamper lowering or cause the vehicle to fall from the rack (Fig. 21)

ENSURE THAT YOU PAY CLOSE ATTENTION TO LOADING OF THE CAR ON THE LIFT ARM TO GET THE CORRECT BALANCE.

ALL PERSONNEL/EMPLOYEES USING THE LIFT SHOULD BE TRAINED BY A COMPETENT SUPERVISOR ON HOW TO LOAD AND OPERATE THE LIFT CORRECTLY.

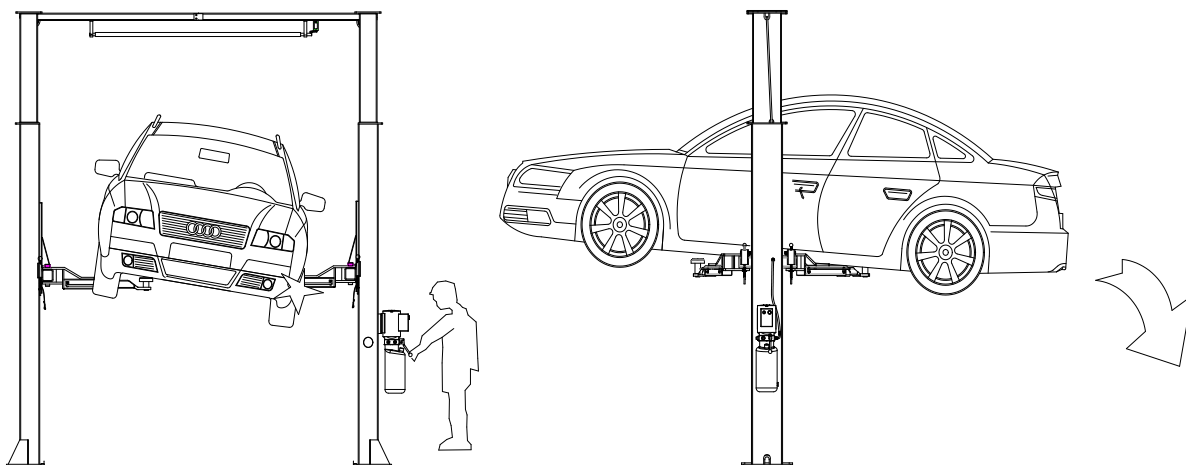

Fig. 21

3.6.6 SLIPPING

Beware of the risk of slipping due to spilt lubricants in the surrounding area.

ALWAYS KEEP THE AREA SURROUNDING THE LIFT CLEAN BY REMOVING ALL OIL SPILLS.

To avoid the risk of slipping, ensure the use of anti-slip footwear.



Fig. 22

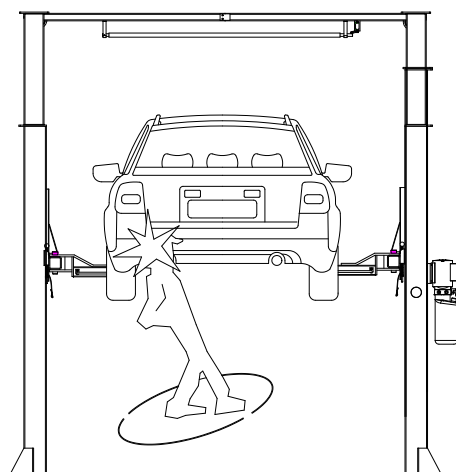

Fig. 23

3.6.7 RISK OF ELECTRIC SHOCK

To eliminate the risk of electric shock, do not use jets of water, steam (high pressure wash units), or solvents in the vicinity of the electrical wiring housing. Do not paint in the immediate vicinity of the lift.

Special care must be taken to keep such substances clear of the electrical command panel. Fig.24

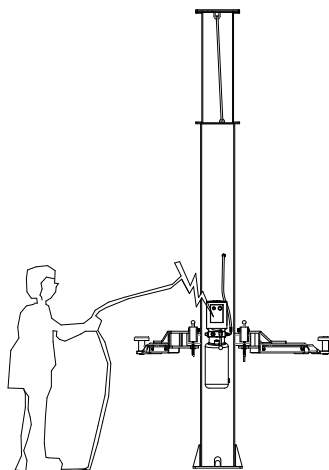

Fig. 24 Risk of electrical shock

3.6.8 RISK RELATED TO INAPPROPRIATE LIGHTING

The operator and the maintenance fitter must ensure that all the areas of the lift are properly and uniformly illuminated in compliance with optics principle and the laws in force in the place of installation.

3.6.9 RISK OF COMPONENT FAILURE DURING OPERATION

The manufacturer has used appropriate materials and construction techniques in relation to the specified use of the lift in order to manufacture a reliable and safe lift. Note however, that the lift must be used in conformity with the manufacturers directions and the frequency of inspections and maintenance work recommended in chapter 6 “MAINTENANCE” **must be observed**.

Take all the necessary precautions to **AVOID ACCIDENTAL START-UP OF THE LIFT**

Use the key switch on the control box to isolate power.

Ensure that all safety precautions are taken in compliance with Work Cover/Work Safe authority in the state in which the Lift is installed.

3.6.10 RISK RELATED TO IMPROPER USE

Personnel are not permitted to stand or sit on the platforms during the Lift maneuver or when the vehicle is in the raised position. (Fig. 25) All uses of the Lift other than the use for which it was designed are liable to give rise to serious accidents involving the persons working in the immediate vicinity of the unit. It is therefore essential to adhere scrupulously to all regulations regarding use, maintenance and safety contained in this manual.

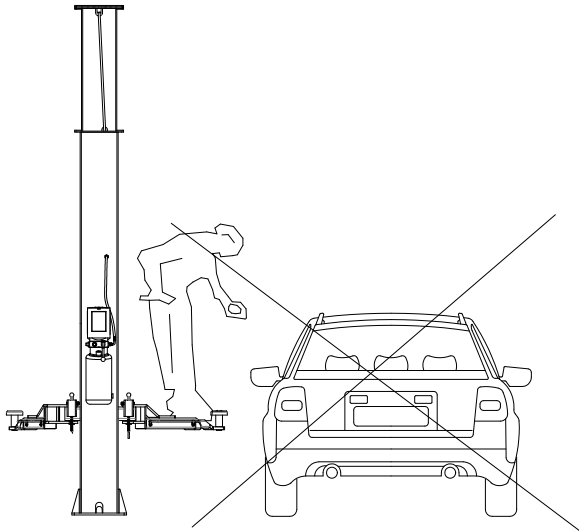

Fig. 25

CHAPTER 4 - INSTALLATION

TO AVOID INJURY TO PERSONNEL OR DAMAGE TO THE LIFT, EXPERIENCED/QUALIFIED INSTALLERS MUST PERFORM THE FOLLOWING OPERATIONS.

4.1 INSTALLATION REQUIREMENTS

The Lift is designed for installation in enclosed areas suitably protected from the weather. The place of installation must be well clear of areas destined to washing or painting, and away from solvent or paint storage areas or areas where there is a risk of a potentially explosive atmosphere.

POSITIONING DIMENSIONS SUITABILITY

The Lift must be installed in observance of the clearances between walls, pillars, other machines, etc. indicated in Fig.26 and in compliance with any legislative requirements in the county of installation.

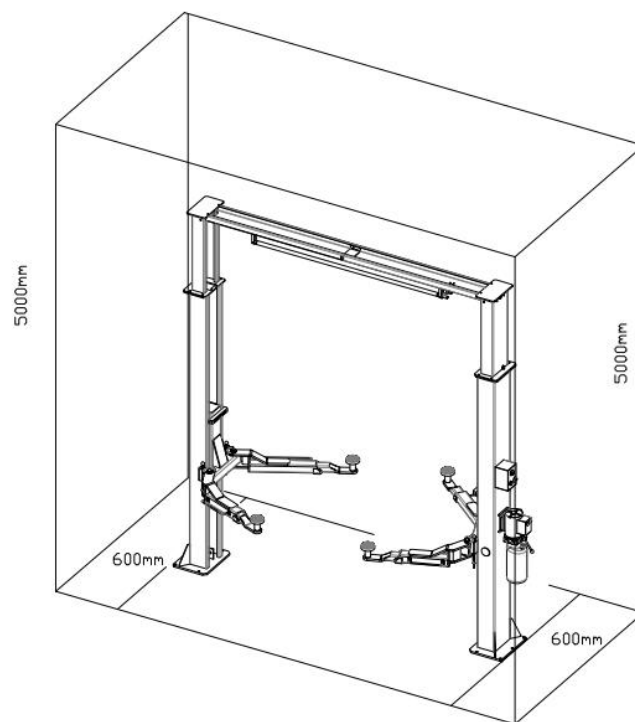

Fig. 26

Essential checklist:

1. Maximum height of arms: 1800mm
2. Minimum distance from walls: 600mm
3. Minimum working area: 600mm
4. Area for command station
5. Area for maintenance, access and emergency escape routes.
6. Position in relation to other machines.

4.2 LIGHTING

All parts of the machine must be uniformly lit with sufficient light to ensure that the adjustment and maintenance operations specified in the manual can be performed without areas of shadow, reflected light and glare. Avoid all situations that could cause eye fatigue.

The lighting must be installed in accordance with the laws in force in the place of installation (responsibility lies with the electrician)

4.3 FLOOR

The Lift must be installed on a horizontal concrete bed with a minimum thickness of 150mm built and a resistance $\geq 30\text{N/mm}^2$. The floor must also be flat and level (10mm of tolerance for leveling).

Consult the manufacturer with regard to special applications.

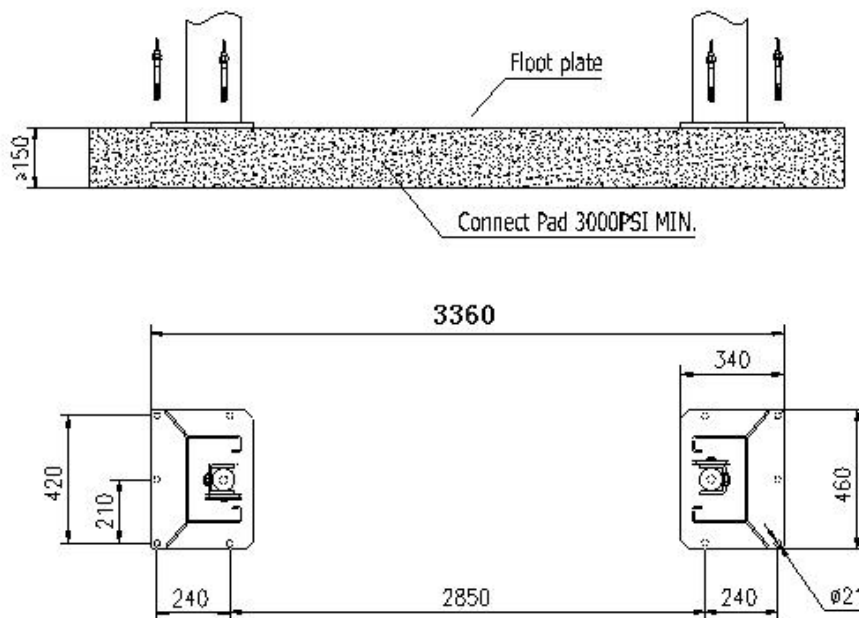

Fig. 27

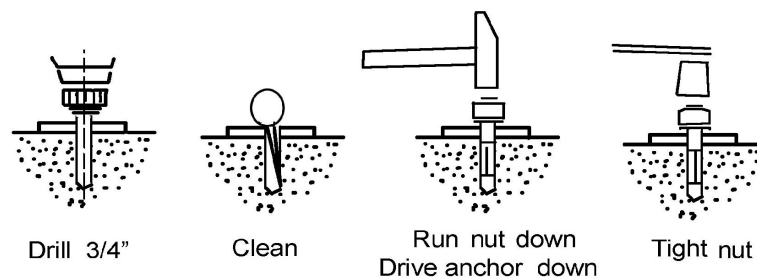

Fig. 28

4.4 ASSEMBLY

 **WARNING**

ONLY AUTHORISED PERSONNEL ARE PERMITTED TO ASSEMBLE THE LIFT.

The weight of the various parts is to be considered in order in order to provide a lifting machine with the maximum lifting capacity of 4500kg.

Prior to assembling the Lift, check that the crate contains all the required materials.

4.4.1 POSTS ASSEMBLY

1. Mount the command post
2. Assemble the hydraulic station on the command post with the screws fixed on the installation panel of the hydraulic station.

4.4.2 LIFT CABLE ASSEMBLY Fig. 29

1. Check the accessories of the Lift to ensure that nothing falls from the lift.
2. Lift both carriages onto the first safety latch.
3. Beginning on the left hand side, take the cable that is in that post up over the top pulley and then down and under the bottom pulley and across the floor to the opposite post and up into the carriage.
4. You will see a locating hole, pass the cable through this hole and apply the lock nuts. Adjust the two M16 nuts, ensuring they are both equally tightened. The cables will need to be adjusted so that they are firm, not loose or over tightened. This will need to be adjusted after the hydraulics and electrical has been connected and the lift is ready to commission.

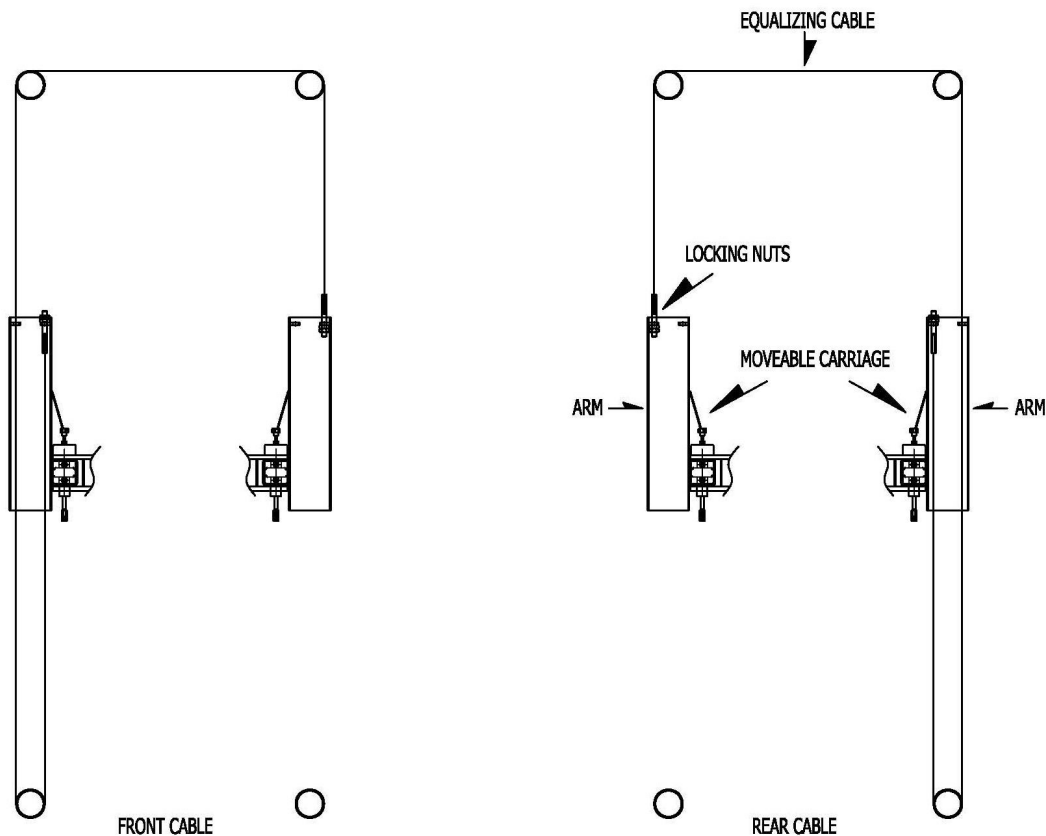

Fig. 29

Repeat for the right post.

5. Check and lubricate the mechanical safety locks located inside the carriage assembly, to ensure that it working freely.

The equalizing cables allow for any differentiation in hydraulic pressure from side to side.

Prior to the Lift leaving the factory, it has been installed, checked and tested.

4.4.3 HYDRAULIC SYSTEM ASSEMBLY

The hydraulic station, high-pressure oil pipe and cylinder have been packed respectively to ensure safe and convenient transportation. Open the box and check the accessories of the hydraulic system, and then continue to assemble the hydraulic system.

1. Mount the complete pump station on the command post with the connecting holes.
2. Hook up the hydraulic line from the pump to base of the post with the hose provided. Two hoses are provided; the longer hose connects the command post cylinder to the slave post cylinder. Ensure that they are tightened accordingly.
3. Fill the hydraulic oil tank reservoir with 12 liters of 32 grade hydraulic oil.
4. Check that all connecting points have no leaks when in operation.

4.4.4 ARM ASSEMBLY

1. Raise the carriages to the first lock latch and rest onto the locks.
2. Mount arms into position on the carriage supports lining up the locating holes.
3. Grease the locating pins to lock the arms into position.

Asymmetric Type

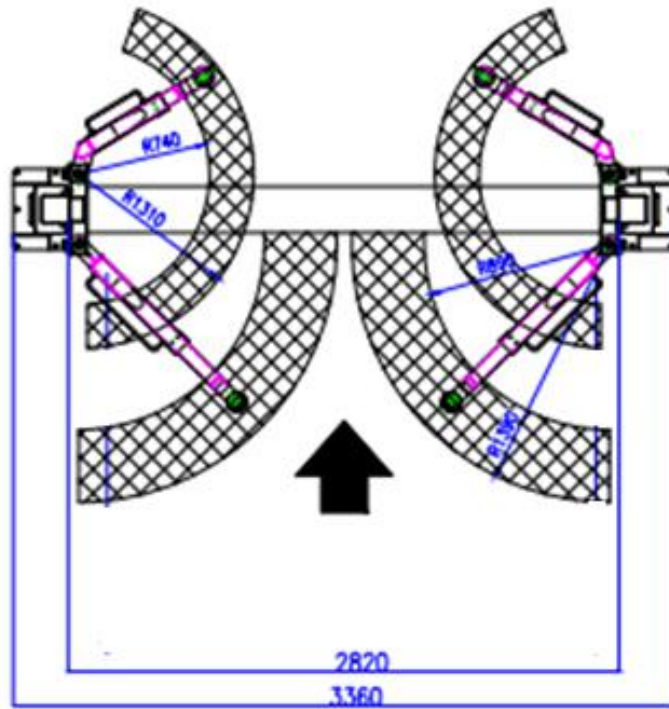

Fig. 30

This mechanism uses two compression springs, one in the main shaft and one under the cap.

4. Repeat the same operations for assembling the other 3 arms.

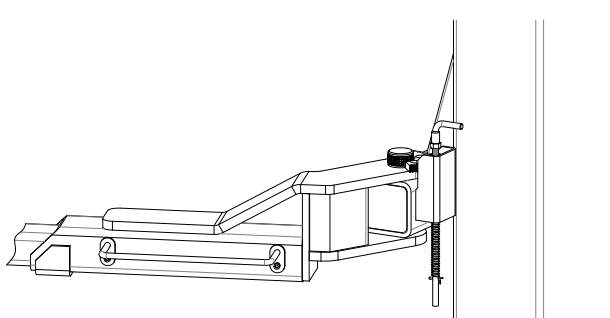

Fig. 31

4.4.5 ELECTRIC MOTOR CONNECTION



WARNING

Skilled personnel must perform the operations listed below

Refer to diagram for electrical connection of the motor. Fig 30 (next page) All connections for power are made to the terminal block, **not key switches**.

Ensure that the following points are observed.

1. Wiring of the motor must be performed by a Licensed Electrician
2. The power supply plant to the Lift is equipped with the protection device required by current standards in the country where the machinery is installed.
3. The power supply line has the following cross-section:

Lift voltage 240V 20 Mp, single-phase.....	minimum 4mm ²
Lift voltage 415V, three-phase.....	minimum 2.5mm ²
Control circuit.....	minimum 4mm ²

4. The voltage oscillations are within the tolerance range set forth by the specifications.
The manufacturer supplies the rack to operate at 240V with a single-phase configuration; if the line voltage is different, the motor and other parts and components must be changed.
The voltage is the same. Check the accessories of the electrical system of the Lift to ensure they are not loose. Pay attention to the limit switches connection and breaker (fuse).

Ensure that the motor is running in a clockwise rotation.

4.5 TESTING AND CHECKING TO PERFORM PRIOR TO START-UP

4.5.1 MECHANIAL TESTS

1. Attachment and tightness of bolts, fittings and connections
2. Free movement of all moving parts
3. Ensure the lift is clean and free of debris
5. Raise and lower the lift and lubricate where necessary

4.5.2 ELECTRICAL TESTS

1. Ensure connection complies with diagrams provided in this manual
2. Ensure that the Lift is correctly earthed (check with Electrician)

4.5.3 OPERATING OF THE FOLLOWING DEVICES

1. Ensure that the limit switch is adjusted and set

4.5.4 HYDRAULIC OIL TEST

1. Ensure that there is sufficient oil in the tank
2. Ensure there are no oil leaks
3. Raise and lower the lift several times to bleed trapped air from Cylinders

4.5.5 ROTATION DIRECTION TEST

The motor should turn in the direction of the arrow located on the power unit pump (clockwise); check using brief start-ups (each start-up must last a maximum of two seconds). If problems arise in the hydraulic oil plant, see the "Trouble-shooting" table in chapter 7.

4.6 SET UP



THESE OPERATIONS MUST ALWAYS BE PERFORMED BY QUALIFIED TECHNICIONS

**AUTHORISED TO CARRY OUT MAINTENANCE SERVICE AND INSTALLATION AS INDICATED
IN THE FRONT OF THIS MANUAL**

4.6.1 VACUUM TEST (without vehicles loaded)

Check the following:

- The up, down and parking push buttons operate correctly;
- The rack reaches the maximum height;
- There are no abnormal vibrations in the posts or in the arms;
- The safety wedges enter the iron pads under the carriage
- The rise limit switches trip
- The electromagnet trips
- After having done all as previously recommended, the height difference between the arms of the two carriages is less than 1cm. On the contrary, adjust their level by working on the counter nuts on the synchronous steel cables.

To perform the tests listed about, complete two or three complete up and down cycles. This is also to be done in order to make the air in the hydraulic circuit going out.

4.6.2 LOAD TESTS

Repeat the previous tests with the vehicle on the rack.

Once the load test has been performed, visually inspect the Lift ensuring that all bolts are tightened.

CHAPTER 5 - OPERATIONS AND USE

5.1 CONTROLS

The Lift Controls are shown in Fig.32

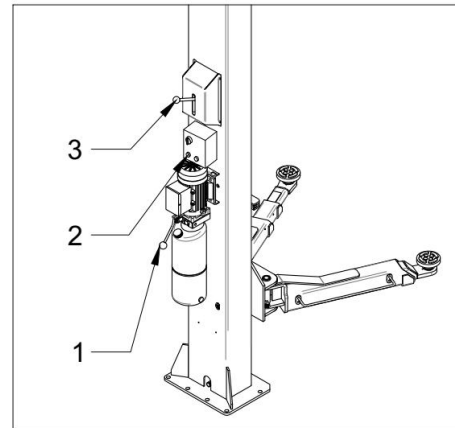
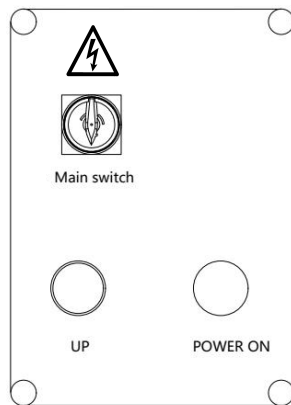

5.2 Fig. 32 Controls

To raise the lift

- Positioning the vehicle between columns.
- Adjust lift arms so that the vehicle is positioned with the centre gravity between the pads. Make sure the arm safeties are engaged.
- Raise the lift by pressing the lifting button until the lifting adaptors contact underside of the vehicle.
- Make sure the vehicle is secured.
- Raise the lift by pushing the lifting button until reaching the desire height.
- Press the safety button to engage the safety.
- Always ensure that the safety in each column is engaged before any attempt is made to work on or near the vehicle.

5.3 To lower the lift

- In case that the lift safety is engaged, push the lifting button to rise the lift a little bit to clear of safety at first;
- Pull the unlock handle until the safety catch released
- Lower the vehicle by pressing the lower handle: the lift will descend;
- Before removing vehicle from the lift area, position the lift arms to and pads to provide an obstructed exit;
- Never drive over the lift arms.

5.4 To lock the lift

- Lifting the vehicle to suitable position;
- Be sure the safety area is free of people and objects;
- Press lower handle ;

CHAPTER 6 – MAINTENANCE

6.1 PRECAUTIONS



ONLY SKILLED PERSONNEL familiar with the lift must carry out maintenance.

When performing maintenance on the Lift, follow all the necessary precautions to **PREVENT THE LIFT FROM BEING STARTED ACCIDENTALLY:**

1. Isolate the power at the key lock.
2. Ensure that the key is kept in a safe place.
3. While maintenance is being performed on the Lift, always keep in mind all the possible risks and the safety instructions as indicated in chapter 3 “Safety - Risk of electric shock” at the machine power supply terminal strip.

IT IS PROHIBITED TO PERFORM MAINTENANCE ON THESE PARTS SUCH AS OIL CYLINDER, AIR CYLINDER AND GEAR PUMP. IF THESE PARTS ARE DAMAGED, THEY SHOULD BE REPLACED.



To ensure correct operating maintenance, see below:

1. Only use original spare parts and tools that are suitable for the job and in good condition
2. Follow the maintenance schedule indicated in the manual: these frequencies are indicative and must always be considered as general rules to be respected.
3. Good preventive maintenance requires constant attention and continuous supervision on the machine. Quickly find the cause of any abnormalities such as excessive noise, overheating, leaking fluids, etc.

Special attention is required for:

1. The condition of Lifting parts (cylinder, power unit)
2. Safety devices (micro switches, pneumatic push and safety wedges)

To perform maintenance correctly, refer to the following documents supplied by the rack manufacturer:

1. Complete functional diagram of the electric equipment and auxiliary equipment indicating the power supply connections.
2. Hydraulic diagram with lists of parts and max. Pressure values.
3. Exploded drawings with the data needed to order spare parts
4. List of the possible causes of malfunctions and recommended solutions (chapter 7 of the manual)

6.2 PERIODIC MAINTENANCE

6.2.1 OPERATION FREQUENCY

To keep the Lift working at full efficiency, follow the indicated maintenance schedule. The manufacturer will not be responsible and will not honor the warranty as a result of non-compliance with the instructions indicated above.

 **NOTE** The frequency indicated refers to normal operating conditions; different frequencies will apply to particularly server conditions.

ALL MAINTENANCE OPERATIONS MUST BE PERFORMED WITH THE POWER ISOLATED

Once the lift has been installed, check:

1. Anchor bolts and fixings are secured
2. That the opposite carriages arms are at the same level
3. The hydraulic unit oil is at the required level

6.2.2 EVERY MONTH

HYDAULIC POWER UNIT

1. Check the oil level of the oil tank, using the special dipstick, which is attached to the filler cap. If necessary, add oil through the cap to reach the required level.
For the type of oil, see page 10 "TECHNICAL SPECIFICATIONS".
2. After the first 40 hours of operation, check the pressure oil contamination level. (Clean the filter and replace the oil if there is a high level of contamination).

HYDRAULIC CIRCUIT

Check that there are no oil leaks in the circuit between the pump, oil pipe and cylinder and in the cylinder itself. In the case of an oil leak, check the condition of the gaskets and replace them, if necessary.

6.2.3 EVERY 3-MONTHS

SYNCHRONOUS CABLE

1. Check that the opposite carriages arms are at the same level
2. Check the tightness of locking nuts and counter nuts on the steel cable threaded ends

HYDAULIC PUMP

1. Under normal operating conditions, check that there is no change in the noise in the motor and gear pump
2. Check that the relative bolts are properly tightened.

SAFETY SYSTEMS

1. Check the operating condition and efficiency of safety devices (described in Chapter 3) and the wear on the safety-locking ladder and relative hinge pins. Lightly grease the locking ladder. Look for excessive wear in the locking ladder. Repair or replace where necessary.
2. Check that the post base anchor bolts and the connection bolts are sufficiently tightened to the ground.

3. Clean and lubricate the carriage slip block and guides.
4. Check that all screws are tightened
5. Check that the arm locking system works properly.
6. Grease all the moving parts.

6.2.4 EVERY 6-MONTHS

HYDRAULIC PUMP

1. Check the contamination or aging level of the oil. Contaminated oil is the main cause of malfunctions of the valves and leads to a brief service life of the gear pumps.
2. Under normal operating conditions, check for changes in the noise of the motor and gear pump.
3. Check the relative bolts are appropriately tightened.

EQUALIZING CABLE

1. Check that both of the carriage arms are at the same level.
2. Check the tightness of locking nuts and counter nuts on the steel cable threaded ends.
3. Control the cable wear by checking diameter, possible broken wires or other damage/relevant changes.
4. Grease the cable with a paintbrush in order to avoid corrosion or breakage due to oxidization.

6.2.5 EVERY 12-MONTHS

1. General check: visual inspection of all structural and mechanical parts to ensure that there are no problems or anomalies.
2. Electric plant: Licensed Electricians should test the electric plant, including the motor of the power unit, cables, limit switch and control box.

HYDRULIC OIL

To replace the hydraulic oil:

1. Lower the Lift to the minimum height (on the ground)
2. Disconnect the power supply to the Lift
3. Drain the oil from the hydraulic circuit, unscrewing the plug located at the base of the power unit reservoir
4. Close the drain plug at the base of the unit
5. Fill the power unit with a funnel through the filler hole located at the top of the power unit reservoir. The oil must be filtered. Oil specifications – Hydraulic Oil Grade 32 or equivalent
6. Close the filler hole
7. Operate Lift in 2 or 3 cycles (height 20-30 cm) to purge oil through the system & bleed all air from circuit.

CHANGING OIL: use only new recommend oil or equivalent; do not use deteriorated stored old oil.

FOLLOWING MAINTENANCE OPERATIONS, RETURN THE LIFT TO THE INITIAL POSITION.

To ensure correct maintenance, it is important to:

1. Use only original spare parts

2. Use only tools that are suitable for the job
3. Follow the minimum maintenance schedule as indicated
4. Immediately find the cause of any abnormalities (excessive noise, overheating, leaking fluids, etc)
5. Pay special attention to Lifting parts (cylinders) and safety devices
6. Use all the documentation supplied by the manufacturer (wiring diagrams, etc)

6.3 PERIODIC LUBRICATION

Lubricate all moving parts of the Lift periodically. Non-contaminated grease must be used. Old or contaminated grease may damage the lubricated parts.

CHAPTER 7 - TROUBLESHOOTING

7.1 TROUBLESHOOTING GUIDE

Troubleshooting and possible repairs require absolute compliance with **ALL SAFETY**

PRECAUTIONS indicated in chapter 6 “MAINTENANCE” and chapter 3 “SAFETY”

POSSIBLE PROBLEMS AND SOLUTIONS

PROBLEM	POSSIBLE CAUSES	SOLUTION
The Lift does non rise when the push button is pressed (motor does not run)	<ol style="list-style-type: none"> 1. Burnt fuse 2. Power 3. Broken limit switch 4. Burnt out motor 	<ol style="list-style-type: none"> 1. Replace fuse 2. Electrician to check 3. Replace limit switch 4. Replace motor
The Lift does non rise when the push button is pressed (motor runs)	<ol style="list-style-type: none"> 1. Insufficient hydraulic oil 2. Drain solenoid valve opened 3. Max pressure valve working 4. Leaks in the hydraulic circuit 	<ol style="list-style-type: none"> 1. Top up oil level 2. Check electric connections or change the valve 3. Take load down 4. Repair the line
Lift continues to rise after releasing the up button	<ol style="list-style-type: none"> 1. Faulty push button 	<ol style="list-style-type: none"> 1. Unplug the Lift & call Service Center
Lift does not descend	<ol style="list-style-type: none"> 1. Foreign object in Lift 2. Solenoid valve blocked 3. Malfunction in the electric motor 4. Carriages jammed on security lock 5. Hydraulic valves have tripped 	<ol style="list-style-type: none"> 1. Remove object 2. Change valve or call Service Center 3 Contact Electrician 4. Follow the correct descent sequence <p>Check for excessive wear or movement in carriage</p> <ol style="list-style-type: none"> 5. Repair damage to the hydraulic circuit damage
The Lift does not rise to the maximum height	<ol style="list-style-type: none"> 1. Oil level is insufficient 2. Vehicle has tripped the end of the stroke bar 	<ol style="list-style-type: none"> 1. Add oil into power unit oil tank 2. This working is correctly.
After having released the up button, the Lift stops and lowers slowly	<ol style="list-style-type: none"> 1. The pipeline of the hydraulic valve dose not close because it is dirty 2. Defective drain valve 	<ol style="list-style-type: none"> 1. At the same time set the rise and descent movements, to clean the valve 2. Replace or call Service Center

The power unit motor overheats	<ol style="list-style-type: none"> 1. Motor malfunction 2. Wrong voltage 	<ol style="list-style-type: none"> 1. Electrician to check 2. Check voltage
Power unit pump is noisy	<ol style="list-style-type: none"> 1. Dirty oil 2. Incorrect assembly 	<ol style="list-style-type: none"> 1. Change oil 2. Call Service Center
Air leakage from cylinder	<ol style="list-style-type: none"> 1. Damaged gaskets 2. Dirt in the plant 3. Damaged valves 	<ol style="list-style-type: none"> 1. Change the damaged gaskets 2. Clean all parts 3. Replace valves

CHAPTER 8 - STRUCTURE AND ACCESSORIES LIST

8.1 STRUCTURE DIAGRAMS

- Positioning the vehicle between columns.
- Adjust lift arms so that the vehicle is positioned with the centre gravity between the pads. Make sure the arm safeties are engaged.
- Raise the lift by pressing the lifting button until the lifting adaptors contact underside of the vehicle.
- Make sure the vehicle is secured.
- Raise the lift by pushing the lifting button until reaching the desire height.
- Press the safety button to engage the safety.
- Always ensure that the safety in each column is engaged before any attempt is made to work on or near the vehicle.

5.3 To lower the lift

- In case that the lift safety is engaged, push the lifting button to rise the lift a little bit to clear of safety at first;
- Pull the unlock handle until the safety catch released
- Lower the vehicle by pressing the lower handle: the lift will descend;
- Before removing vehicle from the lift area, position the lift arms to and pads to provide an obstructed exit;
- Never drive over the lift arms.

5.4 To lock the lift

- Lifting the vehicle to suitable position;
- Be sure the safety area is free of people and objects;
- Press lower handle ;
 - Positioning the vehicle between columns.
 - Adjust lift arms so that the vehicle is positioned with the centre gravity between the pads. Make sure the arm safeties are engaged.
 - Raise the lift by pressing the lifting button until the lifting adaptors contact underside of the vehicle.
 - Make sure the vehicle is secured.
 - Raise the lift by pushing the lifting button until reaching the desire height.
 - Press the safety button to engage the safety.
 - Always ensure that the safety in each column is engaged before any attempt is made to work on or near the vehicle.

5.3 To lower the lift

- In case that the lift safety is engaged, push the lifting button to rise the lift a little bit to clear of safety at first;
- Pull the unlock handle until the safety catch released

- Lower the vehicle by pressing the lower handle: the lift will descend;
- Before removing vehicle from the lift area, position the lift arms to and pads to provide an obstructed exit;
- Never drive over the lift arms.

5.4 To lock the lift

- Lifting the vehicle to suitable position;
- Be sure the safety area is free of people and objects;
- Press lower handle ;

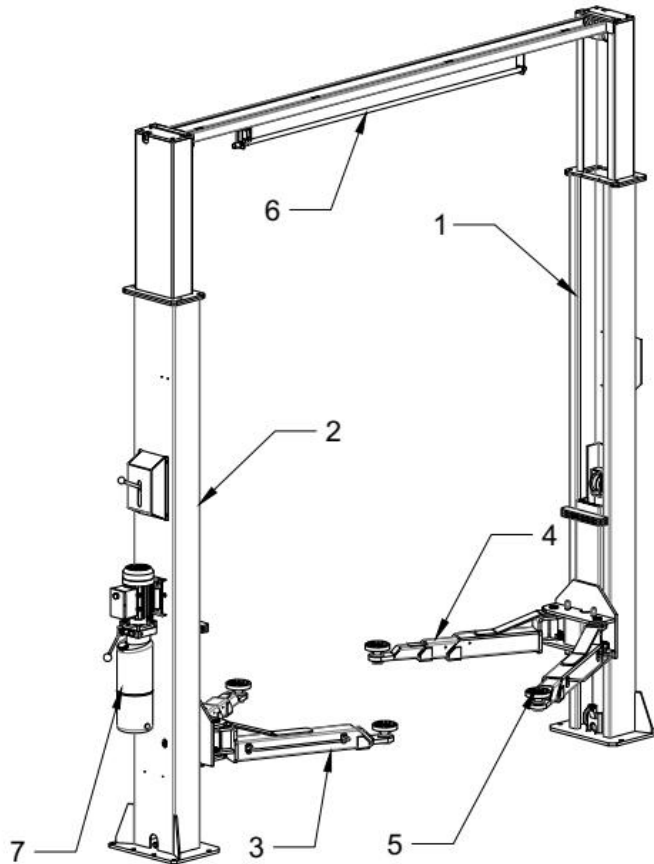

1	Main post groupware
2	Sub-post groupware
3	Long arm groupware
4	Short arm groupware
5	arm groupware of sub-post
6	Cover
7	Pump station

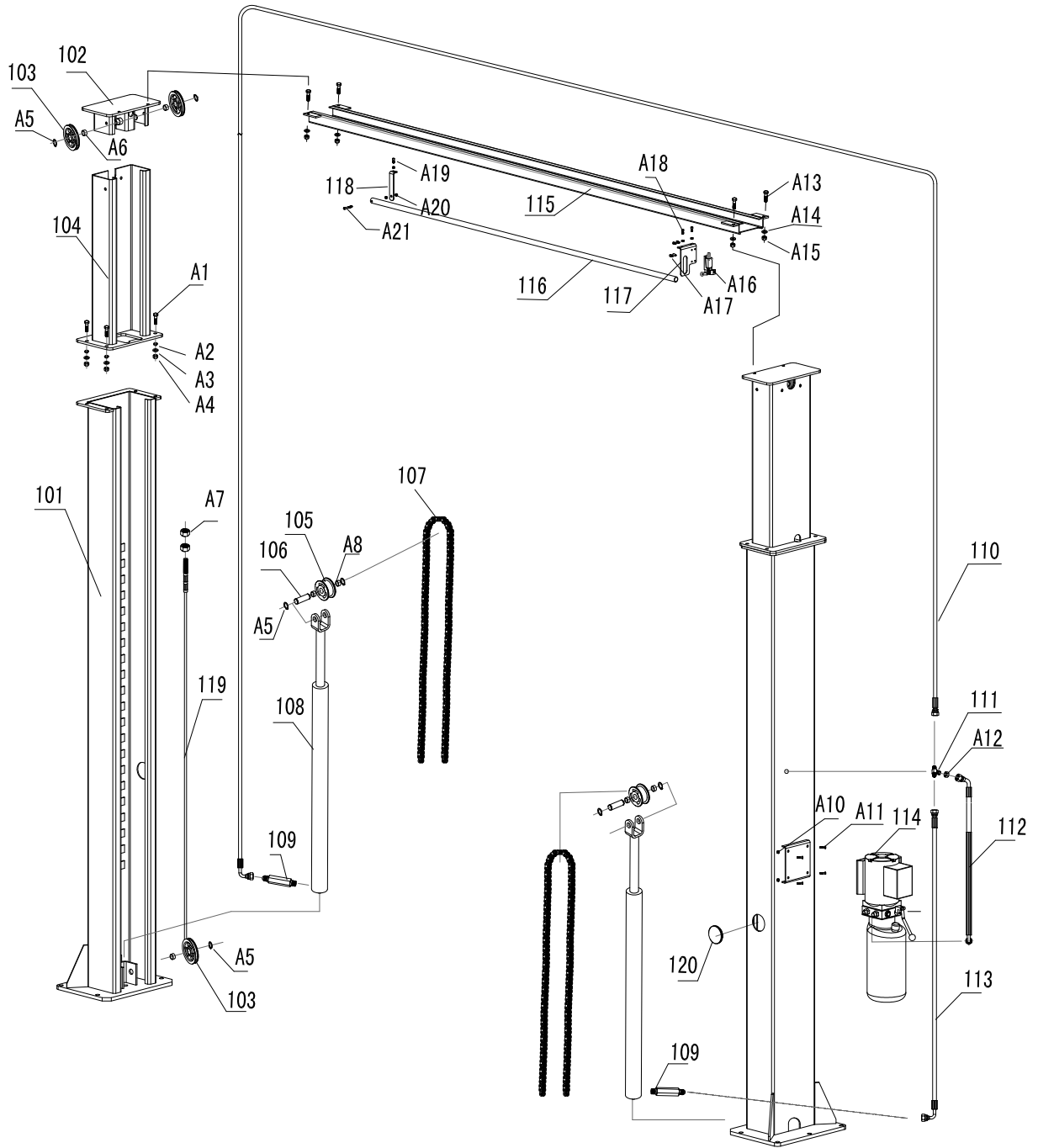

8.2 COMPONENTS LIST

8.2.1

No.	Part Name	No.	Part Name
A1	Hexangular bolt M12×35	101	Main- post
A2	Flat washer 12	102	Cover board
A3	Spring washer 12	103	Idler pulley
A4	Nut M12	104	Sub-post
A5	Seeger ring 25	105	Chain wheel
A6	Oil free bearing 2515	106	Chain axle
A7	Nut M16	107	Chain
A8	Oil free bearing 2520	108	Cylinder
A9	Combined washer 14	109	Tubing Pipe tie-in
A10	Nut M8	110	Long Tubing
A11	Nut M8×30	111	Three tubing connector
A12	Nut M14	112	Tubing
A13	Nut M10×30	113	Short Tubing
A14	Flat washer 10	114	Pumping
A15	Nut M10	115	Upper beams
A16	Limit switch YBLX-ME/8108	116	End of stroke bars
A17	Nut M5×16	117	Limit switch Bracket
A18	Nut M5	118	End of stroke bar support
A19	Nut M6×25	119	Steel wire
A20	Nut M6	120	Cover
A21	Nut M6×50		

CHAPTER 9 – Regular information

EC DECLARATION OF CONFORMITY

The equipment which accompanies this declaration is in conformity with EU Directive(s):

2006/42/EC Machinery Directive

2006/95/EC Low Voltage Directive

2004/108/EC Electromagnetic Compatibility Directive

APPENDIX A-SPECIAL NOTES

A.1 DISPOSAL OF USED OIL

Used oil, which is removed from the power unit and the plant during an oil change, must be treated as a polluting product, in accordance with the legal prescriptions of the country in which the Lift is installed.

A.2 DISMANTLING OF LIFT

DURING LIFT DISMANTLING, ENSURE THAT YOU COMPLY WITH ALL SAFETY PRECAUTIONS DESCRIBED IN CHAPTER 3 (ALSO VALID FOR ASSEMBLY)

Authorised technicians must dismantle the Lift. Metal parts can be scrapped as iron. In any case, all the materials deriving from the dismantling must be disposed of in accordance with the current standards of the country in which the Lift is installed.

APPENDIX B SPARE PARTS

B.1 SPARE PARTS

When replacing parts and performing repairs, ensure that you comply with ALL SAFETY PRECAUTIONS described in chapter 6 MAINTENANCE and in chapter 3 SAFETY

B.2 PROCEDURE FOR ORDERING SPARE PARTS

To order spare parts:

1. Indicate the serial number of the Lift and the year built
2. Indicate the code of the piece requested (see the CODE columns in the tables)
3. Indicate the quantity required.

The request must be submitted to the authorized reseller as indicated in the front of the manual.