

0.5T TRANSMISSION JACK

TJ-90104



INSTRUCTION & MAINTENANCE MANUAL



Read this entire manual carefully and completely before installation or operation of the 0.5T transmission jack

1. Forward

This jack is a removal hydraulic one that with the following advantage compact construction:light in weight,long lift range,fast in lift,replaceable in connection part,firmly and reliable in connection of ADT and so on.

It can be used when assembling and disassembling the removal parts and structural parts which need to be lifted,descended transported. It is the ideal tool for assembling and repairing in motor repair shop,mobile shop.

2. Main specifications

Safe working capacity (kg)	Min height of saddle (mm)	Max height of saddle (mm)	Net weight(kg)	Dimensions(mm)
500	870	1800	80	550*370*900

3. Safety instructions

WARNING! Ensure all preliminary checks are carefully carried out before use of jack.

Ensure use of genuine parts only. Non authorised parts may be dangerous and will invalidate the warranty.

WARNING! Use jack on level and solid ground. Ensure the floor over which the jack will be transported is swept clean.

DANGER! DO NOT use on tarmacadam, or any other soft surface as jack may sink or topple. Serious personal or fatal injury may result.

DANGER! If jack tips or leans STOP WHAT YOUR ARE DOING. MOVE QUICKLY TO A SAFE DISTANCE. DO NOT TRY TO HOLD OR STEADY JACK. Serious personal or fatal injury may result.

WARNING! Ensure load is placed level and centrally on jack saddle and load is fixed in place before attempting to lift, lower, or transport.

WARNING! DO NOT operate jack if any parts are damaged or missing.

4. Main construction

PART NO	DESCRIPTION	QTY	PART NO	DESCRIPTION	QTY
1	Screw	2	35	Seal	2
2	Washer	2	36	Screw	4
3	Nut	2	37	Screw	1
4	headstock Accessories	2	38	Steel ball	1
5	headstock	1	39	Seal	1
6	Nut	1	40	Valve core	1
7	Seal	1	41	Valve core pin	1
8	Seal	1	42	Spring	1
9	Small top cap	1	43	Steel ball	1
10	Seal	1	44	Spring	1
11	piston rod	1	45	Washer	1
12	Seal	1	46	Screw	1
13	Seal	1	47	oil-out foot pedal base	1
14	Seal	1	48	Screw	4
15	Big top cap	1	49	Steel pin	1
16	Seal	1	50	Cotter Pin	2

17	Seal	1	51	oil-out foot pedal	1
18	Middle cylinder	1	52	locking block	1
19	spring plate	1	53	Screw	1
20	Spring	1	54	Connecting Rod	2
21	Pump core	1	55	Screw	2
22	Seal	1	56	Cotter Pin	2
23	Seal	1	57	Steel pin	2
24	Seal	1	58	Long foot pedal pin	1
25	Pump body	1	59	Screw	2
26	Pump washer	1	60	Foot pedal	1
27	Steel ball	1	61	Washer	4
28	Cylinder washer	1	62	Spring Washer	4
29	Base	1	63	Screw	4
30	Cylinder	1	64	Round nut	4
31	Screw	1	65	Washer	4
32	Seal	1	66	Spring washer	4
33	Coat	1	67	Caster wheels	4
34	valve seat	1	68	Foot	2

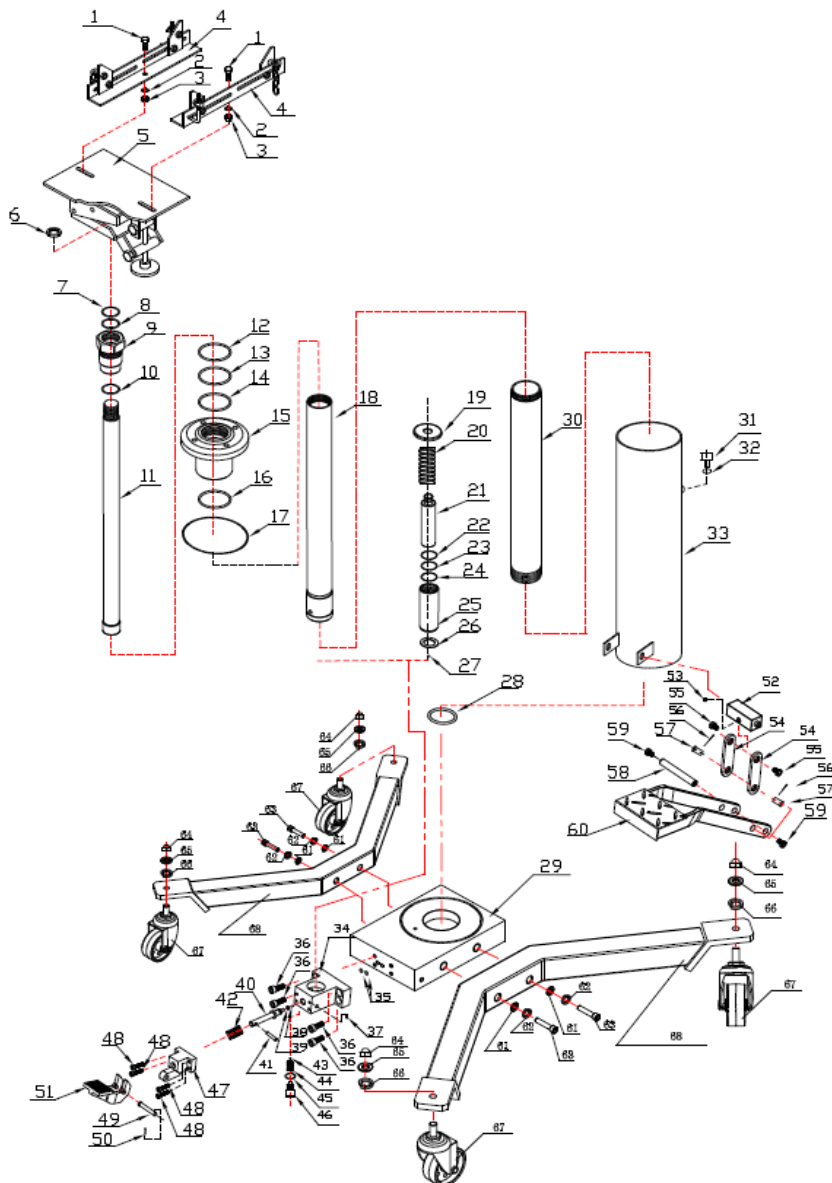

5. Operation instruction

WARNING! Before use ensure you have read, understood and apply Section 3 safety instructions.

WARNING! Ensure you prepare vehicle correctly before attempting to use the Transmission Jack.

5.1. POSITIONING JACK BENEATH LOAD.

Before use ensure the transmission weight and size does not exceed the capacity of the jack.

5.1.1. Ensure the vehicle from which the gearbox is to be removed is correctly positioned, handbrake applied and raised to allow the transmission jack to be positioned correctly.

5.1.2. Ensure there are no other persons around or under the vehicle.

5.1.3. Ensure saddle is in its lowest position and use handle to transport and centrally position jack beneath vehicle transmission.

5.1.4. Pump the jack foot peddle and the saddle will rise.

5.1.5. When saddle is just beneath the transmission re-adjust alignment if necessary to centralise the saddle.

5.2. LOWERING THE LOAD.

WARNING! Ensure the load is central and stable on the jack saddle and load is fixed in place before attempting to lift, lower, or transport.

SLOWLY turn the release valve knob anti-clockwise to GENTLY lower saddle to the lowest minimum height before attempting to transport load.

IMPORTANT: The unit is fitted with a .Dead Man. release valve. The quicker the valve knob is turned the more rapid the jack's descent.

Ensure the jack's descent is slow and controlled to avoid the risk of sudden dropping which could be dangerous.

The valve will automatically return to the closed position when the knob is released.

5.3. TRANSPORTING THE LOAD.

WARNING! Ensure you have read, understood and apply Section 1 safety instructions.

5.3.1. Ensure the jack saddle is fully lowered and load is fixed in place before attempting to lift, lower, or transport.

5.3.2. Transport the load over level and solid ground, preferably concrete, and ensure the floor is swept clean beforehand.

5.3.3. Be diligent in continually monitoring the load in transit. Keep all other persons at a safe distance.

Note this jack may be used with appropriate adaptors in order to handle such components as rear axle units and transfer cases that are within the weight limitations of the jack.

5.4. RE-INSTALLING A GEARBOX.

To transport, reposition beneath a vehicle, and raise a load up, reverse the procedures outlined above.

6. Maintenance

IMPORTANT: Only fully qualified personnel should attempt maintenance or repair.

6.1. When the jack is not in use, the saddle must be in the lowest position to minimise ram and piston corrosion.

6.2. Keep the jack clean and wipe off any oil or grease. Lubricate all moving parts with acid free oil.

6.3. The oil cylinder is a sealed unit and must not be accessed. For service contact your authorised dealer.

WARNING! Only a good quality Jack oil must be used, DO NOT use brake fluid.

6.4. Before each use, follow the pre-check list to ensure components are in good working order. If any suspect item is found remove jack from service and take necessary action to remedy the problem.

DO NOT use the jack if you believe it has been subjected to an abnormal load or shock. If in doubt contact your local service agent.

6.5. Periodically check the pump piston and piston rod for signs of corrosion. Clean exposed areas with a clean oiled cloth.